





**RECEIVER**  
 AS SHOWN

**SPEED CONTROL**  
 AS SHOWN

**BATTERY MOUNT**  
 AS SHOWN  
 LAID DOWN

**TRANNY TYPE:**  
 DIRECT DRIVE  
 GEAR BOX

**TRANNY LOCATION:**  
 FORWARD  
 REAR

**SERVO MOUNT**  
 AS SHOWN  
 DIRECT/NOSE

**ADDED WEIGHT:**  
 FRONT \_\_\_\_\_  
 MIDDLE \_\_\_\_\_  
 REAR \_\_\_\_\_

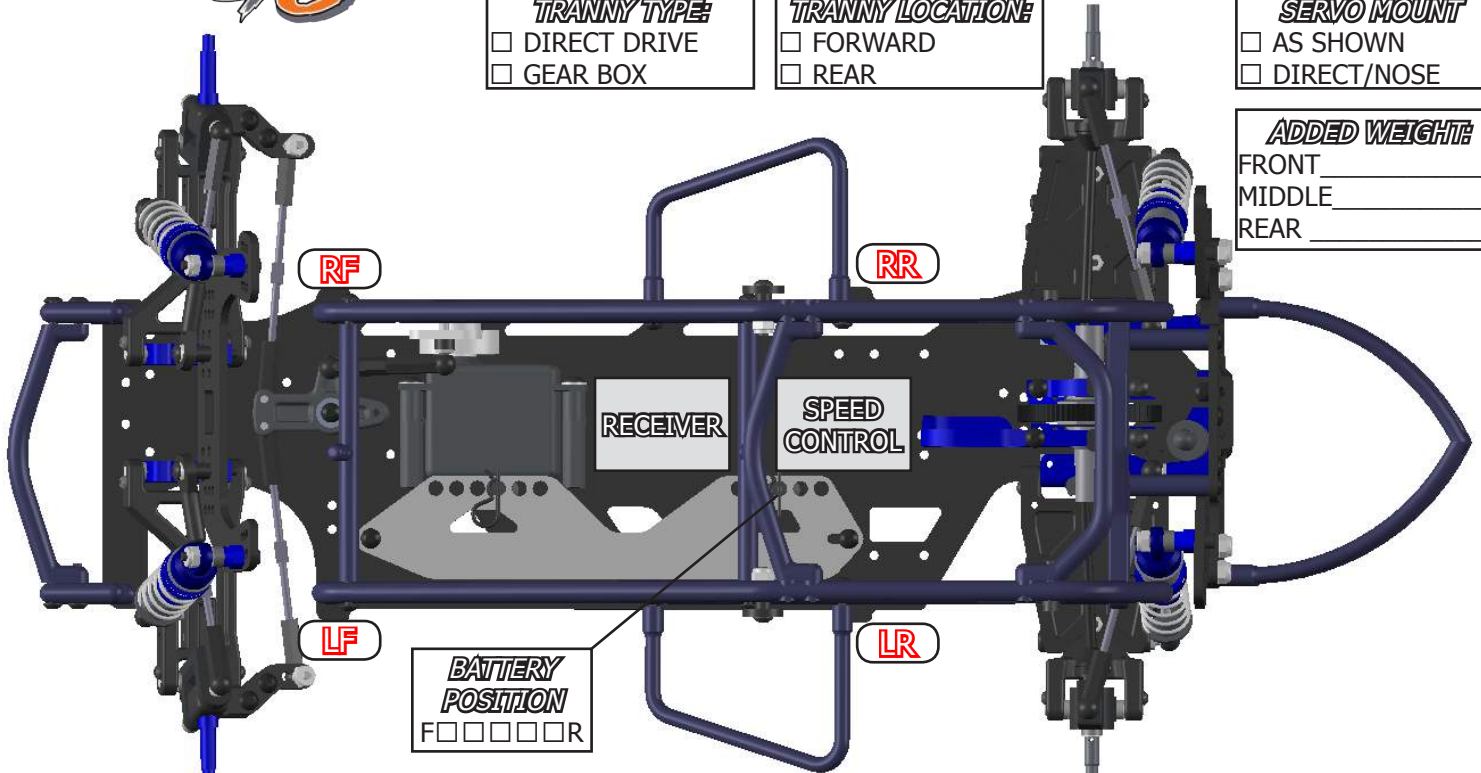

-MEASURED "RACE READY" WITHOUT THE TOP WING

<b>RIDE HEIGHTS BY LOCATION:</b> LF: _____ RF: _____ LR: _____ RR: _____ <b>MEASURED FROM:</b> <input type="checkbox"/> TOP OF CHASSIS <input type="checkbox"/> BOTTOM OF CHASSIS	<b>CORNER WEIGHTS:</b> LF: _____ RF: _____ LR: _____ RR: _____ <b>OVERALL:</b> _____	<b>MAX CHASSIS HEIGHT:</b> LF: _____ RF: _____ LR: _____ RR: _____ <b>MEASURED FROM:</b> <input type="checkbox"/> TOP OF CHASSIS <input type="checkbox"/> BOTTOM OF CHASSIS
---	---	---

**POWER SETTINGS**  
 MOTOR: \_\_\_\_\_  
 AMP DRAW: \_\_\_\_\_  
 TIMING: \_\_\_\_\_  
 PINION: \_\_\_\_\_  
 SPUR: \_\_\_\_\_  
 SPEED CONTROL: \_\_\_\_\_  
 "BLINKY"  OPEN  
 SETTINGS: \_\_\_\_\_  
 BATTERY: \_\_\_\_\_  
 MOTOR TEMP AFTER RUN: \_\_\_\_\_

**AERO**

**MAIN WING**  
 6X6  
 7X7

**FRONT WING**  
 NONE  SMALL  
 LARGE

**HOOD TYPE**  
 TRADITIONAL  
 SCOOP (HIGH DF)

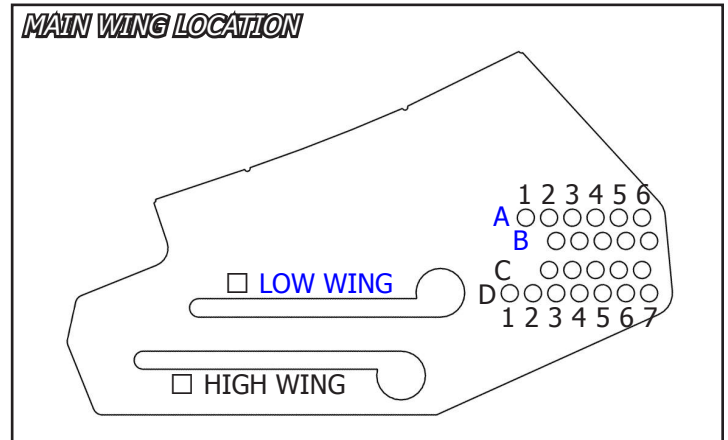

**NOTES:**

---



---



---



---



---