



DRIVER: Arnie Fie
 DATE: 1/29/2012
 EVENT: IceBreaker
 CLASS: 4wd 13.5 Open
 TRACK: Cherryville, NC LENGTH: _____

Clay Hard Packed Loose Dirt
 Carpet Asphalt Concrete
 Flat Banked True Oval Tri-Oval
 Traction: High Medium Low

FRONT SUSPENSION

LEFT CAMBER: +3
 CAMBER LINK LOCATION: OUTER INNER
 CAMBER RATE SHIMS: 0

TOE IN/OUT: +.06
 RF: LEAD TRAIL
 AMOUNT: _____
 SWAY BAR: NONE .063" .078"

RIGHT CAMBER: -2.5
 CAMBER LINK LOCATION: OUTER INNER
 CAMBER RATE SHIMS: 0

ACKERMANN: ON SPINDLE
 SHORT MIDDLE LONG
 KICKUP: NONE 1.5° 3°

CASTOR: 0° 5° 10° 15°
 AXLE SHIMS: .125
 INNER PIVOT ANGLE (LEFT): STOCK (3°) _____
 AXLE SHIMS: 0
 INNER PIVOT ANGLE (RIGHT): STOCK (3°) _____
 CASTOR: 0° 5° 10° 15°

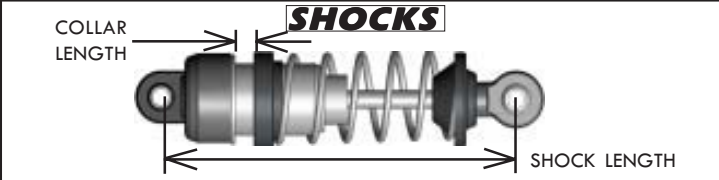

SHOCKS

LEFT FRONT SHOCK
 BODY LENGTH: SHORT MED LONG
 SHAFT LENGTH: SHORT MED LONG
 SPRING: CW Green 7#
 OIL: 50 PISTON: M
 BLADDER: Black
 LENGTH: 2.40
 COLLAR: .300

RIGHT FRONT SHOCK
 BODY LENGTH: SHORT MED LONG
 SHAFT LENGTH: SHORT MED LONG
 SPRING: CW Green 7#
 OIL: 50 PISTON: M
 BLADDER: Black
 LENGTH: 2.40
 COLLAR: .275

REAR SUSPENSION

LEFT CAMBER LINK LOCATION: OUTER INNER
 R.C. HEIGHT: HIGH LOW

SWAY BAR: NONE .063" .078"
 REAR WIDTH (NARROW OR WIDE): _____
 TOE-BLOCK SHIMS: LR: .100 RR: .100
 ANTI-SQUAT SHIMS: LR: 3deg RR: 3deg

RIGHT CAMBER LINK LOCATION: INNER OUTER
 R.C. HEIGHT: HIGH LOW

HUB SPACING: F0000000R
 CAMBER: +2.5
 TOE-IN: -3
 WHEEL SPACERS: 0

HUB SPACING: F0000000R
 CAMBER: -2
 TOE-IN: +1
 WHEEL SPACERS: .125

LEFT REAR SHOCK
 BODY LENGTH: SHORT MED LONG
 SHAFT LENGTH: SHORT MED LONG
 SPRING: CW White 14#
 OIL: 50 PISTON: M
 BLADDER: Black
 LENGTH: _____
 COLLAR: _____

RIGHT REAR SHOCK
 BODY LENGTH: SHORT MED LONG
 SHAFT LENGTH: SHORT MED LONG
 SPRING: CW Red 16#
 OIL: 50 PISTON: M
 BLADDER: Black
 LENGTH: _____
 COLLAR: _____

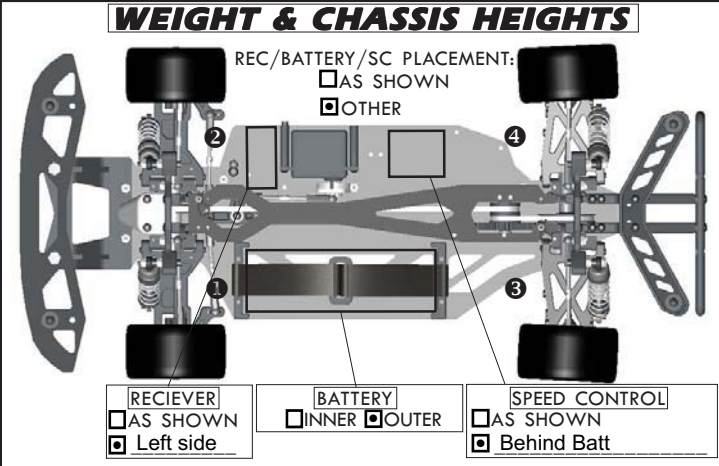

TIRES & TRACTION

TIRE TYPE: FOAM STREET RUBBER LOOSE DIRT
 COMPOUND: _____ DIAMETER: _____ INSERT: _____

RF: CW "25" 2.65
 LF: " " "
 RR: " " "
 LR: " " "

TRACTION ADDITIVE: Magic It clean and dope.

x7 24cross cut all 4

LF RF LR RR

CORNER WEIGHTS:
 LF: _____ RF: _____
 LR: _____ RR: _____

OVERALL WEIGHT: _____

CHASSIS HEIGHTS BY LOCATION:
 1 .540 2 .610
 3 .580 4 .650

MEASURED FROM: TOP OF CHASSIS BOTTOM OF CHASSIS
-NOTE: RADIO TRAY IS .060" HIGHER IN HEIGHT VS CHASSIS.

MISC...

MOTOR: Thunder Power 13.5
 PINION: 25 SPUR: 72
 BODY TYPE: MODIFIED LATE MODEL
 PART# 9070 Keystone
 SPOILER ANGLE: Upper Option
 SPOILER LENGTH: 2"
 WICKERBILL: .250"
 BODY LOCATION FROM A BODY POST: Normal to front wheel wells

-Right side tray and rear bumper mounts removed. -#1004 Rear Body Post mounts directly to bulkheads
 -Servo mounted on left side opposite from stock position,
 -None of the above necessary to run foam, this was a bit of a test versus stock placements for rubber tire vs. running the foam tire.

-DIFF in front, not one-way. For foam & high bite much more stable.
 -Car was a close 2nd to Jody Utt both qual and main. -4.5oz added to make min weight