



DRIVER: Chuck Lonegran
 DATE: _____
 EVENT: _____
 CLASS: Mod Sprint
 TRACK: Pro Scale MI LENGTH: _____

Clay Hard Packed Loose Dirt
 Carpet Asphalt Concrete
 Flat Banked True Oval Tri-Oval
 Traction: High Medium Low

FRONT SUSPENSION

RIGHT		LEFT
CAMBER: <u>-1.5</u>	TOE IN/OUT AMOUNT: <u>0</u>	RF <input type="checkbox"/> LEAD <input type="checkbox"/> TRAIL AMOUNT: <u>0</u>
CAMBER LINK LOCATION <input checked="" type="checkbox"/> OUTER <input type="checkbox"/> INNER	SHOCK POSITION: <input type="checkbox"/> TOP <input checked="" type="checkbox"/> MID <input type="checkbox"/> BOT	CAMBER LINK LOCATION <input checked="" type="checkbox"/> OUTER <input type="checkbox"/> INNER
CAMBER RATE SHIMS: <u>0</u>		CAMBER RATE SHIMS: <u>0</u>
KINGPIN INCLINE <input checked="" type="checkbox"/> 0° <input type="checkbox"/> ANGLED		KINGPIN INCLINE <input checked="" type="checkbox"/> 0° <input type="checkbox"/> ANGLED
ACKERMANN: <input type="checkbox"/> ON SPINDLE <input checked="" type="checkbox"/> SHORT <input checked="" type="checkbox"/> MIDDLE <input type="checkbox"/> LONG	SUSPENSION POSITION RF: <input type="checkbox"/> OUTER <input checked="" type="checkbox"/> MIDDLE <input type="checkbox"/> INNER LF: <input type="checkbox"/> OUTER <input checked="" type="checkbox"/> MIDDLE <input type="checkbox"/> INNER	ACKERMANN: <input type="checkbox"/> ON SPINDLE <input checked="" type="checkbox"/> SHORT <input checked="" type="checkbox"/> MIDDLE <input type="checkbox"/> LONG
FRONT AXLE: <input checked="" type="checkbox"/> STOCK <input type="checkbox"/> EXTENDED	CASTOR: <input type="checkbox"/> 0° <input checked="" type="checkbox"/> +5° <input type="checkbox"/> -5° <input type="checkbox"/> +10° <input type="checkbox"/> -10°	KICK-UP: <input type="checkbox"/> 25° <input type="checkbox"/> 20° HIGH <input checked="" type="checkbox"/> 20° LO <input type="checkbox"/> 15° HIGH <input type="checkbox"/> 15° LO
AXLE SHIMS: <u>Inner</u>	SWAY BAR: <input type="checkbox"/> NONE <input type="checkbox"/> .063" <input type="checkbox"/> .078"	AXLE SHIMS: <u>Inner</u>

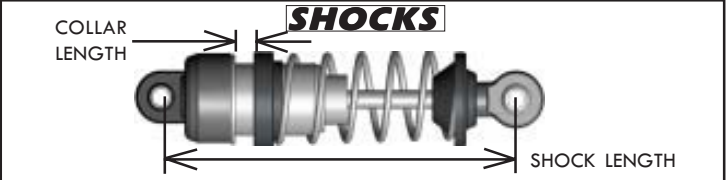

LEFT FRONT SHOCK	RIGHT FRONT SHOCK
BODY LENGTH <input checked="" type="checkbox"/> SHORT <input type="checkbox"/> MED <input type="checkbox"/> LONG	BODY LENGTH <input checked="" type="checkbox"/> SHORT <input type="checkbox"/> MED <input type="checkbox"/> LONG
SHAFT LENGTH <input checked="" type="checkbox"/> SHORT <input type="checkbox"/> MED <input type="checkbox"/> LONG	SHAFT LENGTH <input checked="" type="checkbox"/> SHORT <input type="checkbox"/> MED <input type="checkbox"/> LONG
SPRING: <u>CW Orange 12</u>	SPRING: <u>CW Orange 12</u>
OIL: <u>30</u> PISTON: <u>M</u>	OIL: <u>30</u> PISTON: <u>M</u>
BLADDER: _____	BLADDER: _____
LENGTH: <u>2.47</u>	LENGTH: <u>2.50</u>
COLLAR: <u>.100</u>	COLLAR: <u>.114</u>

REAR SUSPENSION

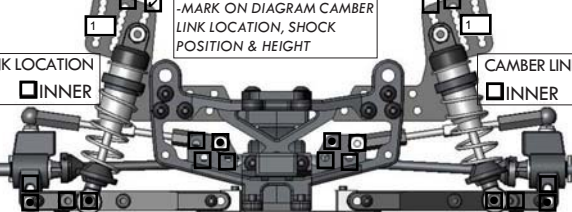
LEFT		RIGHT
CAMBER LINK LOCATION <input checked="" type="checkbox"/> OUTER <input type="checkbox"/> INNER		CAMBER LINK LOCATION <input type="checkbox"/> INNER <input checked="" type="checkbox"/> OUTER
HUB SPACING: <u>FO</u> SHADE IN 4 SPACERS	SWAY BAR: <input checked="" type="checkbox"/> NONE <input type="checkbox"/> .063" <input type="checkbox"/> .078" REAR WIDTH (INNER/OUTER)	HUB SPACING: <u>FO</u> SHADE IN 4 SPACERS
CAMBER: <u>+1.5</u>	LR: _____ RR: _____	CAMBER: <u>-1.5</u>
TOE-IN: <u>-3</u>	TOE-BLOCK SHIMS: _____	TOE-IN: <u>-3</u>
WHEEL SPACERS: <u>.125</u>	ANTI-SQUAT SHIMS: _____	WHEEL SPACERS: <u>.125</u>

-SHADE IN MOUNTING LOCATIONS ON SUSPENSION ARMS, BEARING CARRIER AND SHOCK TOWER.

LEFT REAR SHOCK	RIGHT REAR SHOCK
BODY LENGTH <input type="checkbox"/> SHORT <input checked="" type="checkbox"/> MED <input type="checkbox"/> LONG	BODY LENGTH <input type="checkbox"/> SHORT <input checked="" type="checkbox"/> MED <input type="checkbox"/> LONG
SHAFT LENGTH <input type="checkbox"/> SHORT <input checked="" type="checkbox"/> MED <input type="checkbox"/> LONG	SHAFT LENGTH <input type="checkbox"/> SHORT <input checked="" type="checkbox"/> MED <input type="checkbox"/> LONG
SPRING: <u>CW Red 6</u>	SPRING: <u>CW Red 6</u>
OIL: <u>25</u> PISTON: <u>M</u>	OIL: <u>25</u> PISTON: <u>M</u>
BLADDER: _____	BLADDER: _____
LENGTH: <u>2.67</u>	LENGTH: <u>2.67</u>
COLLAR: <u>.532</u>	COLLAR: <u>.416</u>

TIRES & TRACTION

TIRE TYPE: FOAM STREET RUBBER LOOSE DIRT

COMPOUND	DIAMETER	INSERT
RF: _____	_____	_____
LF: _____	_____	_____
RR: _____	_____	_____
LR: _____	_____	_____

TRACTION ADDITIVE: PB Blaster

LF

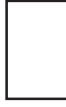
RF

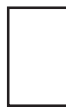

LR

RR

WEIGHT & CHASSIS HEIGHTS

ADDED LEAD:
 FRONT 0
 MIDDLE 0
 REAR 0

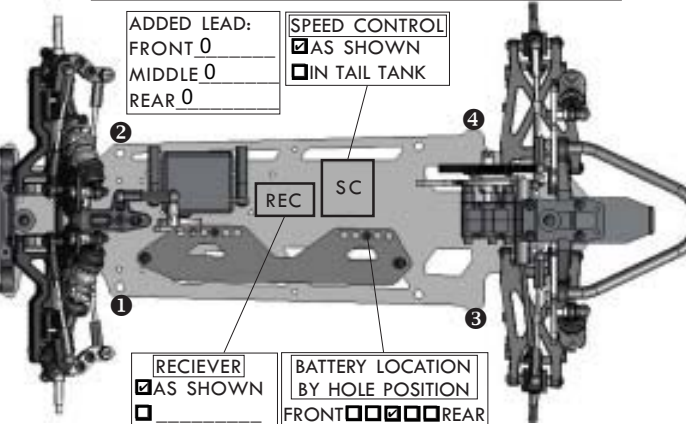
SPEED CONTROL
 AS SHOWN
 IN TAIL TANK



RECIEVER
 AS SHOWN

BATTERY LOCATION
 BY HOLE POSITION
 FRONT REAR

CORNER WEIGHTS:		CHASSIS HEIGHTS BY LOCATION:	
LF: _____	RF: _____	1 .7365	2 .7640
LR: _____	RR: _____	3 .7865	4 .8070
OVERALL WEIGHT: _____		MEASURED FROM: <input checked="" type="checkbox"/> TOP OF CHASSIS <input type="checkbox"/> BOTTOM OF CHASSIS	

WING

MAIN WING SIZE: 6x6 7x7
 FRONT WING SIZE: Large
 SPOILER LENGTH: _____
 WING LOCATION: _____

LOW WING

1 2 3 4 5

HIGH WING

A B C

HOOD TYPE: Salem Hood

MISC...

MOTOR: 13.5
 PINION: 81 SPUR: 32
 SPEED CONTROL: Novak Kinetic
 PUNCH SETTING: Blinky
 INTIAL BRAKE: _____
 AUTO BRAKE: _____

LR Shock: Inner/1hole from top RR Shock: Center/1hole from top
