

# **ENFORCER GSX2**

**THE DOMINANT FORCE IN DIRT OVAL RACING!**

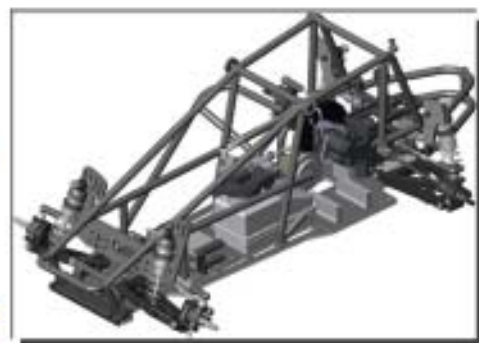

## **#0928 ENFORCER GSX2 RACING KIT**

Manufactured By:

**CUSTOMWORKS**  
**R/C CARS**

760-B Crosspoint Drive  
Denver, NC 28037

[www.customworksrc.com](http://www.customworksrc.com)



## **REQUIRED READING...UNDERSTAND THIS MANUAL!**

Thank You and Congratulations on purchasing the **ENFORCER GSX2!** Within this kit you will find a race winning car with over 21 years worth of **CUSTOM WORKS** design and quality. In order for you to realize this race car's winning potential it is important to follow the written text along with the pictures included. The steps required to build this car are very easy, as long as you read before you build.

The instructional format for building this car is to open each bag in alphabetical order. Each bag of parts will be broken down into "Steps" in the manual. All parts and hardware needed to complete all steps for each separate bag, will be found in each individual bag. There is no need to steal screws from other bags. In the rare event you need to look in a different bag for a certain part, it will be noted clearly.

Considering the various dirt or clay surfaces that Nitro Dirt Oval cars are raced on today, the Enforcer GSX2 has been designed to be competitive on high bite and well groomed clay tracks with rubber or foam racing tires. The instructions will build the kit using the most verastale set-up Custom Works has found in testing on different types of tracks, however there are various other suspension configurations available to you that you may find more suitable for your local track. For updates and more proven set-ups login to CustomWorksRC.com.

All hardware (screws, washers, nuts, etc...) are referred to by size and type in the instructions. To help clarify which screw or nut the instruction is calling for refer to the **HARDWARE REFERENCE** supplement. The size of the screw or nut should match the "shadow" of the same piece very closely.

Screw ID's are: **FH**=Flat Head **BH**=Button Head **SH**=Socket Head **SS**=Set Screw

## **BUILDING TIPS:**

-Using some type of thread locking fluid is suggested for all parts where metal screws thread into other metal parts. We suggest using a lite setting strength thread lock for the reason you may want to take the screw out one day. Remember it only takes a very small amount to secure the screw.

-Do **NOT** use power screwdrivers to drive screws into parts. The fast rotation speed can easily melt and strip plastic parts or cross-thread into the aluminum parts.

-Lightly sand the edges of graphite pieces using a medium grade sandpaper to avoid splinters. Run a thin bead of Super Glue around the edges to give pieces greater durability.

## **SUGGESTED TOOLS**

400 Grit Sandpaper  
Hobby Scissors  
Small Needle Nose Pliers

Wire Cutters  
X-Acto Knife  
Phillips Head Screw Driver

Blue Loctite  
3/16" Wrench

# Bag A Front Suspension



-Parts for Step#1		3332 Qty 1		3255 Qty 2		3258 Qty 2		1255 Qty 2		4240 Qty 2	1:1		5230 Qty 24			
-Parts for Step#2		1201 Qty 1		1242 Qty 1		3228 Qty 1		3228 Qty 1		3228 Qty 1		5253 Qty 4		5263 Qty 4		3229 Qty 1

### STEP #1

- Insert 4240 Inner Pin thru 3332 Susp Brace and thru the first leg of 3253 Susp Arm. The 1255 Spacer will go between the Susp Arm and the 3258 Susp Mount.

- Snap 5230 E-Clips to 4240 Susp Pin.

- Arms should pivot freely on the mounts.

### STEP #2

Screw Mounting Locations for 3257 Suspension Mounts.

- Do NOT over-tighten the screws into the mount!

- Fasten the 1242 tower to the suspension assembly. THE REMAINING HOLES WILL BE COMPLETED IN "Bag B"!

- Fasten the suspension assembly and the 3228 Body Post to the 1201 Chassis.

# Bag B Steering Components



-Parts for Step#1		5225 Qty 4	1:1		5235 Qty 6	1:1		5213 Qty 2		5213 Qty 2		
-Parts for Step#2		3202 Qty 2		7209 Qty 2		7209 Qty 4		7200 Qty 2		5004 Qty 2		
-Parts for Step#3		3203 Qty 2 (Left Shown)		1255 Qty 4		4241 Qty 2	1:1		5230 Bag A	1:1		
		3304 Qty 1		3304 Qty 1		8122 Qty 4		5262 Qty 2		5257 Qty 2		5217 Qty 4

### STEP #1

- Make (2) of each turnbuckle shown below, total of 4 linkages.

- The linkages with ball cups on each end will be STEERING LINKS.

- The linkages with a pivot ball on one end will be CAMBER LINKS.

- NOTE: Turnbuckle has RIGHT and LEFT threads!



## STEP #2

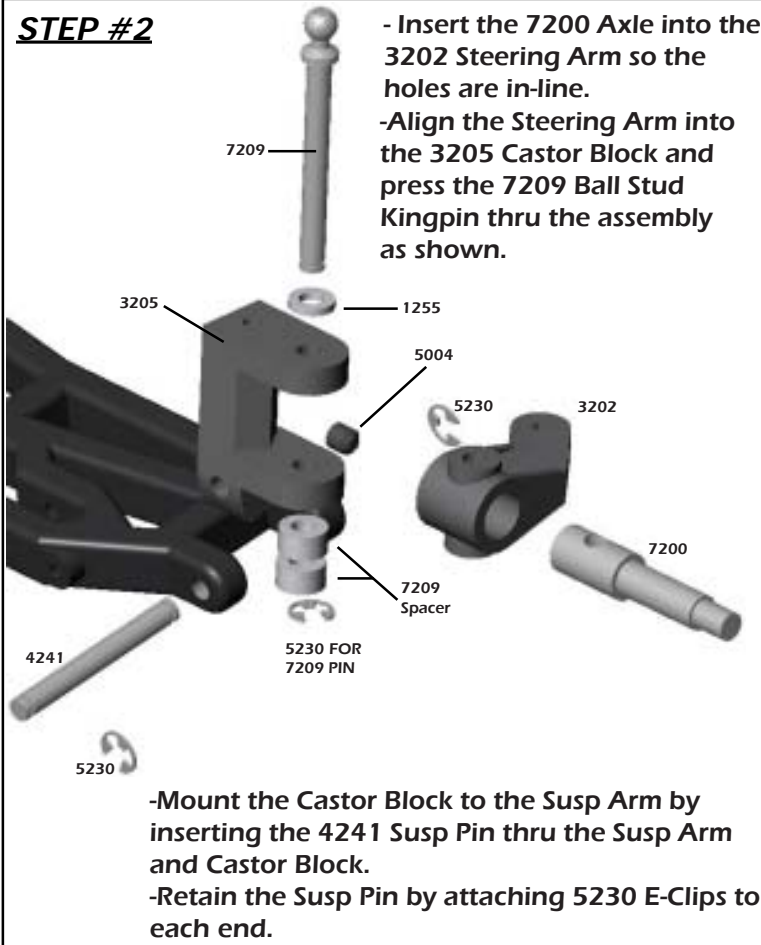

## STEP #3

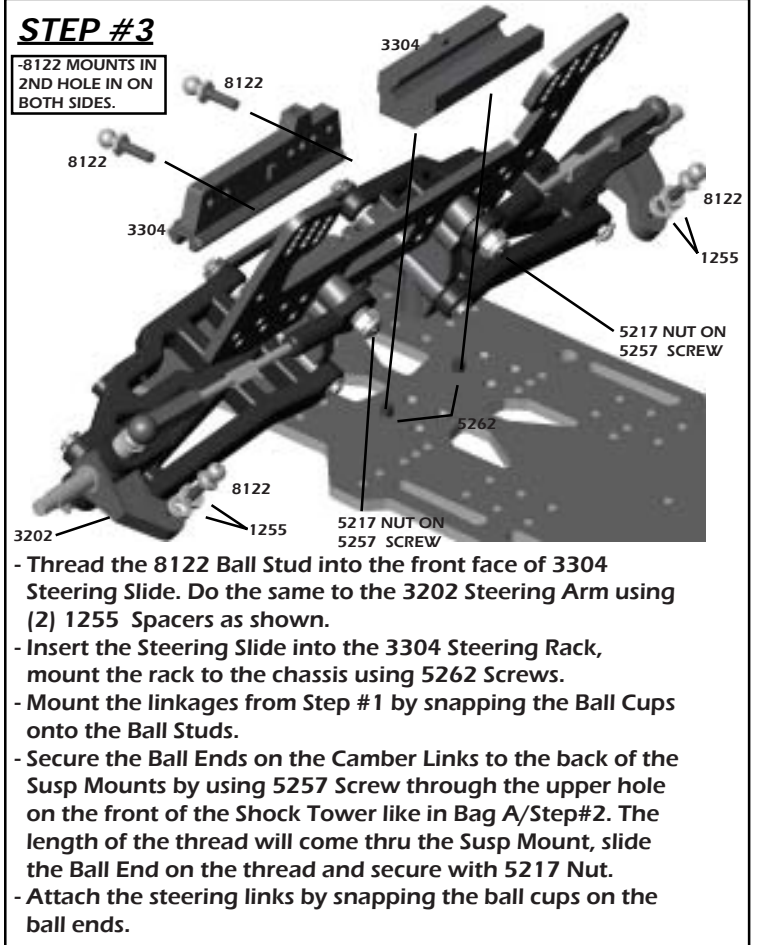

## Bag C Rear Suspension



Part Name	Qty	Ratio
1273 Rear Bulkhead	Qty 1	1:1
1284 Med Shock Ear	Qty 2	1:1
3305 Tail Tank Tray	Qty 1	1:1
5255 4-40 x 5/8 BH Screw	Qty 4	1:1
5263 4-40 x 3/8 FH Screw	Qty 4	1:1
5253 4-40 x 3/8 BH Screw	Qty 2	1:1
5217 4-40 Lock Nut	Qty 4	1:1
3240 Rear Susp Arm	Qty 2	1:1
2222 1-3 Deg Toe Block	Qty 2	1:1
4234 Rear Inner Susp Pin	Qty 2	1:1
5264 4-40 x 1/2 FH Screw	Qty 6	1:1
5230 Bag A E-Clip	Bag A	1:1

## STEP #1



## STEP #2

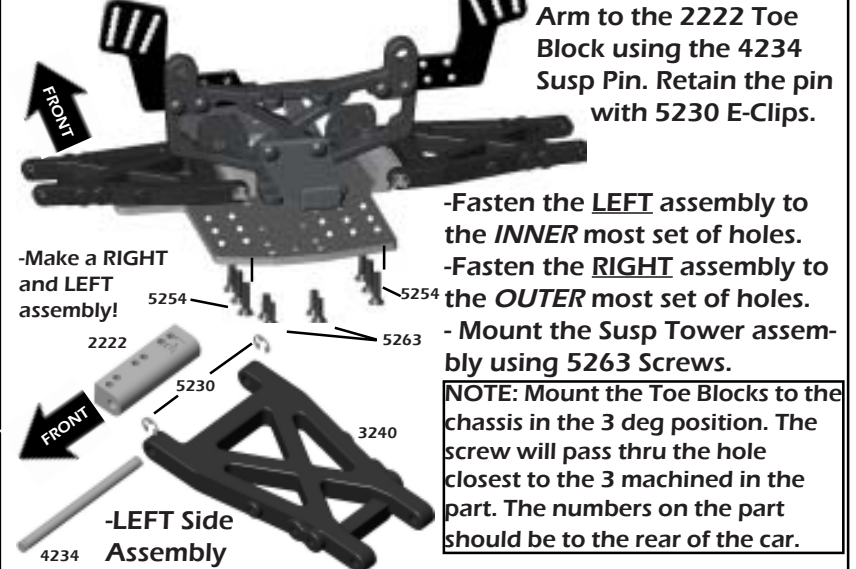

# Bag D Rear Suspension



-Parts for Step#1	3241 Qty 2 Bearing Carrier	1226 Qty 4 Ball Bearing	4235 Qty 2 Rear Outer Susp Pin	1255 Qty 10 Spacer	5230 Bag A E-Clip		
-Parts for STEP#2	7211 Qty 2 CVD Coupling	7215 Qty 1 Short Dogbone	7213 Qty 1 Long Dogbone	7216 Qty 2 Rear CVD Axle	7211 Qty 2 Rear CVD Pin	7211 Qty 2 CVD Set Screw	
-Parts for STEP#3	5223 Qty 1 1 3/4" TI Turnbuckle	5225 Qty 1 2" TI T-Buckle	5235 Qty 4 Ball Cup	7047 Qty 8 Spacer	8122 Qty 4 Ball Stud	7203 Qty 2 Roll Pin	5217 Qty 2 4-40 Lock Nut

### STEP #1

- Press 1226 Ball Bearings into the 3241 Bearing Carrier.
- Attach the Bearing Carrier to the Susp Arm using 4235 Susp Pin with (2) 1255 Spacers on each side of the Bearing Carrier.
- **NOTE: The Suspension Pin will pass thru the UPPER hole in the Bearing Carrier.**
- Retain the Susp Pin using 5230 E-Clips.

### STEP #2

- Apply grease to the areas shown.
- Apply thread-lock (Loctite) to the set screw.
- Align the holes as shown so that the 7211 CVD Pin can pass thru the Bone, Axle, and Coupling. Pin should be evenly spaced in the DogBone.
- Tighten the Set Screw by angling the Bone and Axle so the set-screw is able to be tightened.

### STEP #3

- Assemble the camber links by threading the 5235 Ball Cup on each end. Attach by snapping the Ball Cups onto the Ball Studs. **NOTE: The LONGER link goes on the RIGHT REAR suspension component.**

- Attach the 8122 Ball Stud to the Rear Bulkhead as shown using a 5217 Lock Nut.

- Slide the thick shim packaged with the CVD parts onto the CVD Axle, Insert the CVD assembly by sliding the axle thru the bearings.

- Slide a 1255 Spacer onto the Ball Stud and thread into the Bearing Carrier in the outer most hole.

- Slide (4) 7047 Shims onto the axle and retain using the 7203 Roll Pin. Pin should be evenly spaced in Axle.

# Bag E Diff Assembly



-Parts for Step#1	4403 Qty 1 Right Outdrive	4404 Qty 2 Diff Ring	4205 Qty 2 Thrust Washer	4361 Qty 1 Diff Bolt Cover	4204 Qty 6 Thrust Balls	4361 Qty 1 Diff Bolt	1:1	1229 Qty 2 5/32 x 5/16 Bearing
-Parts for Step#2	4402 Qty 1 Left Outdrive	4362 Qty 1 Diff Spring	4407 Qty 1 Diff Gear	4357 Qty 12 Diff Balls	4361 Qty 1 Diff T-Nut			

### STEP #1

**CUSTOM-TIP!!!**  
 -Using 400 Grit Sandpaper in a "Figure 8" pattern, it is best to sand the surfaces of both the 4404 Diff Ring and 4205 Thrust Washers. The textured surface results in a smoother and longer lasting diff.

- Slide a 4205 Thrust Washer onto the Diff Bolt.
- Apply a thick layer of Black Grease to the Thrust Washer, press (6) 4204 Thrust Balls into the Black Grease.
- Slide the other Thrust Washer on the Diff Bolt and insert it into the 4403 Right Outdrive.
- Press (1) 1229 Bearing into the Outdrive.
- Put (1) 4404 Diff Ring on the Outdrive, apply Diff Lube as shown.

### STEP #2

- Press a small amount of Diff Grease into each of the small holes in the 4407 Diff Gear.
- Press (1) 1229 Bearing and the (12) 4357 Diff Balls into the Diff Gear.
- Put (1) 4404 Diff Ring onto the 4403 Right Outdrive, apply Diff Grease as shown.
- Install the 4362 Diff Spring and 4361 T-nut into the 4402 Left Outdrive.
- Carefully slide the diff assembly together so the Diff Bolt passes thru the entire assembly and threads into the T-nut.
- Screw the Diff Bolt into the T-nut until you feel the Diff Spring fully compress. **DO NOT OVERTIGHTEN!!!**
- Back the Diff Bolt off EXACTLY 1/8 of a turn. Diff motion should be smooth and the Outdrives will turn in opposite directions. Insert Diff Bolt Cover as you did the T-Nut.

# Bag F Transmission Casing



-Parts for Step#1	4401 Qty 1 Transmission Halves (LEFT and RIGHT)	4405 Qty 1 Idler Gear	4370 Qty 6 Thick Spacer	1:1	1226 Qty 4 3/16 x 3/8 Bearing
-Parts for Step#2	1230 Qty 2 3/8 x 5/8 Bearing	4368 Qty 1 Top Drive Shaft	5273 Qty 5 4-40 x 3/8 SH Screw	1:1	4406 Qty 1 Top Shaft Roll Pin

### STEP #1

- Press the (2) 1230 Bearings and (4) 1226 Bearings into each 4401 Transmission Half.
- Slide (1) 4370 Thick Washer on each side of the 4368 Top Drive Shaft.
- Insert the Diff Assembly, Top Drive Shaft, and 4405 Idler Gear into the RIGHT Trans Half.
- Align the LEFT Trans Half over the gears and secure it to the RIGHT Trans Half with (5) 5273 Screws.

- Diff Screw should be on the RIGHT side of the Trans!

### STEP #2

- Press the 4406 Roll Pin into the hole in the Top Drive Shaft.



# Bag G Spur Gear Assembly



-Parts for Bag G		4424 Qty 1		4423 Qty 1		2228 Qty 1		4966 Qty 1		5252 Qty 2		2228 Qty 1		5245 Qty 1
	Disc Brake Adapter		Brake Disc		Slipper Eliminator		66T 32P Spur Gear		4-40 x 1/4 BH Screw		Spacer		5-40 Locknut	

## STEP #1



- First slide the 4424 Disc Brake Adapter onto the 2228 Slipper Eliminator so the grooves are aligned.
- Press the 4423 Brake Disc onto the 4424 Brake Adapter and slide the entire assembly onto the Top Drive Shaft so that the Roll Pin keys into the grooves.
- Secure the assembly to the Top Shaft with the 2228 Spacer and the 5245 Locknut. Do NOT overtighten the nut on the Top Shaft!
- Mount the 4966 Spur Gear so the flat side faces AWAY from the transmission. Secure using (2) 5252 Screws.

# Bag H Brake Assembly



-Parts for Bag H		4420 Qty 1		4421 Qty 1		4422 Qty 1		4425 Qty 1		5252 Qty 2
	Brake Bracket		Brake Shoe		Brake Cam		Clip		4-40 x 1/4 BH Screw	

## STEP #1



- Slide the 4421 Brake Shoe onto the 4420 Brake Bracket with both crescent shape cut-outs facing the same direction.
- Install the Brake Bracket onto the transmission so that the Brake Disc is between the Bracket and Shoe.
- Secure the Bracket using 5252 Screw.
- Slide the 4422 Brake Cam thru the small holes in the Brake Bracket. The lever of the Brake Cam should be facing the same direction as the pictures shown.
- Secure the Brake Cam using 4425 Clip.



# Bag I Transmission Casing



-Parts for Bag I		3309 Qty 1		3229 Qty 1		1202 Qty 1		3265 Qty 1		3229 Qty 1		5264 Qty 4		5253 Qty 4		5268 Qty 2
	Transmission Brace		Post Collar		Trans Spacer		Trans Spacer		8-32 x 1/2 FH Screw		4-40 x 1/2 FH Screw		4-40 x 3/8 FH Screw		4-40 x 1" FH Screw	



- Attach 3229 Body Post to 3309 Trans Brace using 3229 Screw. Slide 3201 Post Collar onto the Body Post and secure using 3229 Set Screw.
- Secure the Trans to the Chassis using (2) 5253 Screws thru the 3265 Trans Support and (4) 5264 Screws thru the 1202 Trans Spacer as shown.
- Attach the Trans Brace to the Trans and Rear Bulkhead using 5253 Screws.
- NOTE: Align the dogbone shafts into the outdrives of Trans as you mount the trans!



# Shock Bag

# Shock Assembly



<b>-Parts for Step#1</b>		1426 Qty 2		1425 Qty 2		1430 Qty 2		1429 Qty 2		1434 Qty 4		1250 Qty 8		1435 Qty 6		1436 Qty 4		5230 Qty 10
<b>-Parts for Step#2</b>		1432 Qty 4		1431 Qty 4		1437 Qty 4		5228 Qty 4		5228 Qty 4								
<b>-Parts for Step#3</b>		1433 Qty 4		1488 Qty 4		1407 Qty 4		1408 Qty 4		5277 Qty 4		5274 Qty 4		2214 Qty 4		5217 Qty 4		

## STEP #1

**NOTE:** Put a few drops of oil on the O-Rings!

**TIP:** To press clip in easiest, compress the clip so the diameter is a little smaller. Insert open end of clip first, working counter-clockwise to the bent end as shown.

**BUILD 2 SHORT & 2 MED LENGTH SHOCKS!**  
 - USE #1429 SHAFT WITH #1425 BODY.  
 - USE #1430 SHAFT WITH #1426 BODY.

## STEP #2

- Snap Pivot Ball into the 5228 Ball End. Thread the Ball End onto the Shock Shaft until the Ball End is flush with the end of threads on the shaft.
- Press 1432 Eyelet Cap into 1431 Threaded Shock Cap so that guide in the Eyelet Cap lines up in the recess in the Threaded Shock Cap.
- Press the 1437 Firm Bladder (BLACK) into the Threaded Shock Cap so the dome of the bladder points away from the Eyelet Cap.
- Fill the Shock Body with oil to the top then thread the Eyelet Cap assembly onto the Shock Body until tight.

**-NOTE:** See shock filling tips for more instructions.

## SHOCK FILLING INSTRUCTIONS: Filling Shocks: Steps 1-4 Setting Shock Rebound: Steps 5-8

- Holding the shock upright, fill with oil until the top of the body. **SUGGESTED 40 WT R/C SHOCK OIL**
- Slowly move the shaft up and down several times to allow air bubbles to escape to the top.
- Refill with oil to the top of the shock body.
- Thread the Eyelet Cap assembly onto the Shock Body until it is hand tight. Oil should seep out of the bleed hole in the Threaded Cap.
- Move the shock shaft in and out a few times and then push it all the way in. It should be easy to push the shaft in until the eyelet hits the body.

- Then the shaft should push itself out to its full length slowly.
- If the shock does not push out this far there is not enough oil in it. Add just a little oil and try steps 5-6 again.
- If the shock rebounds too fast, or you cannot push the shaft in until the eyelet hits the body, there is too much oil. Loosen the cap about X full turns and pump out a small amount of oil by pushing the shaft in. Retighten the cap and try steps 5-6 again.

### STEP #3

**RIGHT FRONT**      **LEFT REAR**

- 5277 Screw passes thru the lowest row, 2nd hole from the outside on both sides.
- 5277 Screw passes thru the inner most hole, 5th hole from the bottom row.
- The thick side of the 1408 Mount Ball should be to the outside on both front and rear.

- Thread 1433 Spring Collar onto the shock. Slide 1488 Spring onto the shock and secure using the 1407 spring bucket as shown.
- Press 5277 Screws thru the locations shown. Fasten using 2214 Standoff.
- Install the shocks onto the screws with the shoulder of the 1408 Mount Ball facing away from the tower, secure with 5217 Nut.
- Attach the shock to the suspension arms in the locations shown.



# Bag J

## Fuel Tank / Motor Mounts



-Parts for Step#1								
	4350 Qty 1 Fuel Tank	3270 Qty 2 Motor Mount	3262 Qty 1 Pipe Mount	5282 Qty 1 4-40 Set Screw	5264 Qty 2 4-40 x 1/2 FH Screw	5263 Qty 3 4-40 x 3/8 FH Screw	5290 Qty 8 M3 x 8MM SH Screw	5217 Qty 2 4-40 Lock Nut

### STEP #1

- Attach the 4350 Fuel Tank to the chassis using the 5263 Screws.
- Mount the 3270 Motor Mounts using the 5290 Motor Mount Screws. The slanted edge of the mount will face toward the spur gear.
- Mount the 3262 Pipe Mount using the 5264 Screws and 5205 Nuts.
- Thread the 5282 Set Screw into the pipe mount, this will be used to secure the wire coming from your exhaust pipe to the car.
- NOTE: The extra 5290 screws are to mount your nitro motor after completion of the Clutch Bag.*

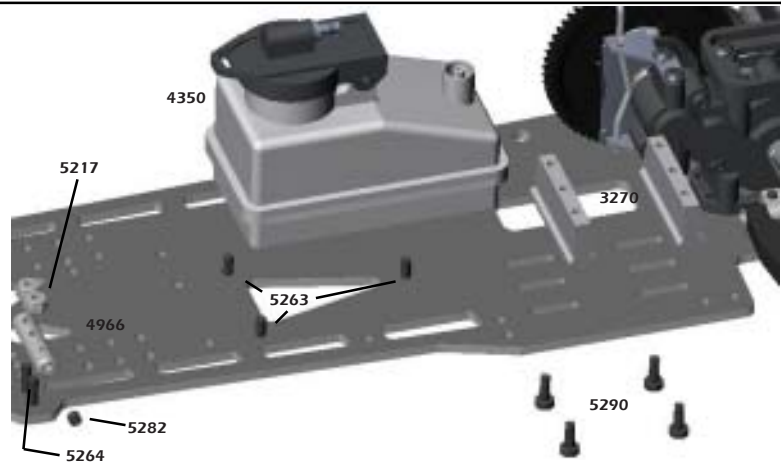

# Bag K

## Servo and Linkage Installation



-Parts for Steps #1&#2									
	5242 Qty 1 Large Servo Saver	5240 Qty 4 Servo Mount	8130 Qty 2 Small Ball Cup	5281 Qty 1 4-40 Stud	8122 Qty 2 Ball Stud	3234 Qty 2 Spacer	3209 Qty 1 Antenna Mount	5253 Qty 8 4-40 x 3/8 BH Screw	5263 Qty 9 4-40 x 3/8 FH Screw
-Parts for Step#3									
	5246 Qty 1 Carb Ball Cup	5246 Qty 2 Spring	5246 Qty 5 Collar	5282 Qty 5 4-40 Set Screw	5246 Qty 1 Swivel	5246 Qty 1 Steel Snap	5246 Qty 1 Servo Horn	5228 Qty 1 Throttle Rod (SHORT)	
-Parts for Step#4									
	5215 Qty 1 2-56 Ball End	5215 Qty 1 2-56 Pivot Ball	5232 Qty 1 2-56 Cone Spacer	5246 Qty 2 Fuel Tubing	5252 Qty 1 4-40 x 1/4 BH Screw	5201 Qty 1 2-56 x 1/2 SH Screw	5204 Qty 1 2-56 Lock Nut	5228 Qty 1 Brake Rod (LONG)	

### STEP #1

- Attach 5240 Servo Mounts to your steering servo in the position shown using 5253 Screws. ALSO do this for throttle servo in the same position as well now.
- Thread 8122 Ball Stud into the upper-most center hole in the 5242 Servo Saver using the 3234 Spacer.
- Attach both 8130 Ball Cups to one another using the 5281 Stud until the Ball Cups bottom out on one another. Snap a Ball Cup onto the Ball Stud on the Servo Saver.
- Determine which of the Spline Inserts are correct for your servo by pressing it over the drive on the servo. Align the servo so it has equal throw in both directions.
- Press the Servo Saver onto the Spline Insert so that the Servo Saver is perpendicular to the servo, attach using the screw that came with your servo.



### STEP #2

- Mount the servos to the chassis using 5263 Screws as shown.
- Thread the 8122 Ball Stud into the top of the Steering Slide, Snap the Ball Cup onto the Ball Stud.
- Using double sided tape, mount your receiver to the top of the steering servo.
- Attach 3209 Antenna Mount in either of the two holes shown below.
- NOTE: Steering movement should be bind free except for the restriction of the servo transmission.*

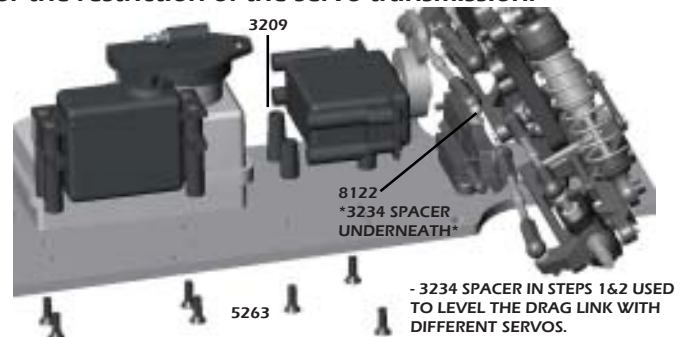

### STEP #3

#### Throttle Rod Assembly:

- Thread the 5228 Throttle Rod into 5246 Ball Cup.
- Slide the parts shown on the Throttle Rod, secure the collars using 5282 set screws.
- Mount the 5246 Swivel onto the Servo Horn thru the outer most SMALL diameter holes. Attach using either the plastic or steel snap-clip.

#### Brake Rod Assembly:

- Thread the 5228 Brake Rod half way into the 5215 Ball End. Press the 5215 Pivot Ball into the Ball End.
- Slide 5246 Collar onto the Brake Rod followed by 5246 Tubing.
- Mount the Brake Rod to the Servo Horn by placing 5201 Screw thru the Pivot Ball and 5232 Cone Spacer into the INNER most hole on the arm opposite the Throttle Linkage Swivel. Secure using 5204 Locknut.

**NOTE:** For illustrative purposes the motor has been placed in the car. You will want to mount the motor after you have completed the Cage assembly step.

#### Installation:

- Slide the open end of the Brake Rod thru the front of the Brake Cam.
- Slide 5246 Tubing Followed by 5246 Collar on the Brake Rod.
- Secure all Collars using 5282 Set Screws.
- Align the servo so it has equal throw in both directions. Press the Servo Horn onto the Servo so that the Servo Horn is perpendicular to the Servo Body as shown. Attach using the screw that came with your servo.
- Trim the remaining length of the Servo Horn on the Brake Linkage side to prevent collision with the Sprint Cage. It may be necessary to bend the Brake Cam upward to allow for proper clearance with the Sprint Cage as well.

#### LINKAGE SET-UP: -To be done with the radio unit ON!

- Keep the servo positioned at idle as shown in **Figure #1!** Might be necessary to re-align both the Steering Servo Saver and the Throttle Servo Horn once the radio is "ON" and the servos find their actual center.

**Throttle Linkage:** Loosen the collar on the right side of the Swivel and slide the Rod so that the carb can fully close. Next slide the right side collar up against the Swivel and tighten. Lastly adjust the left side collar so that it compresses the spring 1/8" to 3/16".

**Brake Linkage:** Slide the Tubing on the Brake Rod so the Tubing is tight to the Brake Cam and the brake is only slightly engaged to the brake pad, there should be slight resistance when trying to spin the spur gear.

-Within your radio locate the End Point Adjustments (EPA) setting. Here you will reduce the amount of travel your servo has so that you do not damage your carb. Notice the carb position in Figure #2, this is FULL throttle to the motor and the servo should pull no further than this.

-Set the Braking End Point so that at full brake (Figure #3) the spring on the throttle linkage is just about fully compressed.

-Set the EPA for the Steering Servo as well, so that it will only turn the amount the car will allow it.

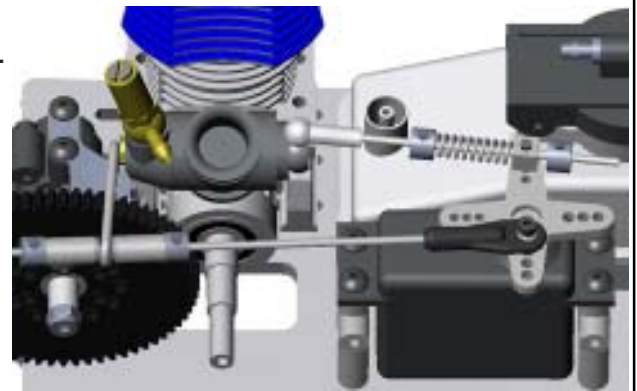



# Clutch Bag Clutch Assembly



-Parts for Clutch Bag										
	4430 Qty 1 Flywheel	4437 Qty 1 Collet	4442 Qty 1 SG Nut	4435 Qty 2 Clutch Shoe	4431 Qty 2 Clutch Spring	4440 Qty 1 Clutch Bell	4523 Qty 1 23T Pinion	4438 Qty 1 Flanged Bearing	4439 Qty 1 Clutch Bearing	5208 Qty 1 M3x6mm SH

- Slide the 4437 Collet onto you motor followed by the 4430 Flywheel.
- Secure the Flywheel using 4442 SG Nut.
- Place the 4435 Clutch Shoes onto the clutch facing the direction shown and secure with 4431 Clutch Springs.
- NOTE:** Install the springs by placing one leg on the Shoe, then press the other leg into the groove in the Clutch Nut using a Driver Wrench.
- Slide 4438 Bearing onto the motor shaft followed by the 4440 Clutch Bell then the 4439 Flanged Bearing.
- Secure the assembly using 5208 Screw. The clutch bell should spin "FREELY" with the screw tight. It is OK if the clutch bell slides back and forth on the motor shaft slightly. If there is too much play use the extra shims provided to correct this.
- Thread the 4523 Pinion Gear onto the Clutch Bell with the side of the pinion with the threads all the way to the edge facing AWAY from the motor.

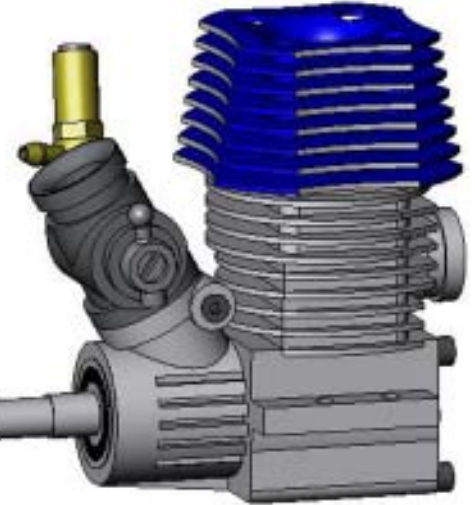

# Cage Bag Cage Assembly



-Parts for Step #1 & Step #2							
	3233 Qty 2 Rear Bumper	3233 Qty 1 Bumper Connector	3239 Qty 1 Front Cage Mount	5255 Qty 4 4-40 x 5/8 BH Screw	5254 Qty 6 4-40 x 1/2 BH Screw	5253 Qty 2 4-40 x 3/8 BH Screw	5262 Qty 2 4-40 x 1/4 FH Screw
-Parts for Step #3 & Step #4							
	3235 Qty 2 Main Cage Half	3233 Qty 1 Front Bumper	3232 Qty 1 Nerf Bar L & R	3232 Qty 1 Nerf Support L & R	3235 Qty 2 Upper Cage Brace	3421 Qty 2 Wing Slide Bushing	
	5278 Qty 2 4-40 x 1 SH Screw	5279 Qty 2 Hole Head Screw LONG	5280 Qty 2 Hole Head Screw SHORT	5274 Qty 4 4-40 x 1/2 SH Screw	5264 Qty 3 4-40 x 1/2 FH Screw		

## STEP #1

- Mount the (2) 3233 Rear Bumpers together using 5253 Screws and the 3233 Bumper Connector.
- Attach the Bumper Assembly to the Rear Bulkhead using 5255 Screw into the upper bumper and 5254 Screw into the lower bumper as shown.

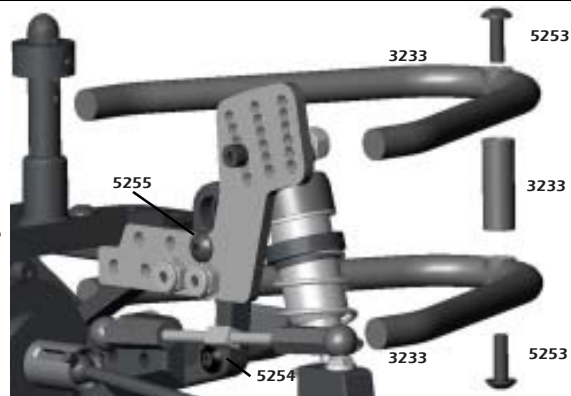



### **STEP #2**

- Mount the 3239 Front Cage mount to the chassis using 5262 Screws.



### **STEP #3**

- Assemble the Nerf Bar and Nerf Bar Support using 5254 Screw.

**NOTE:** Right and Left Nerf Bars and Supports come in the cage kit. Shown is the RIGHT assembled part. When using the correct Support with the Nerf Bar, the bottom foot of the Support and the short leg of the Nerf Bar will be parallel.

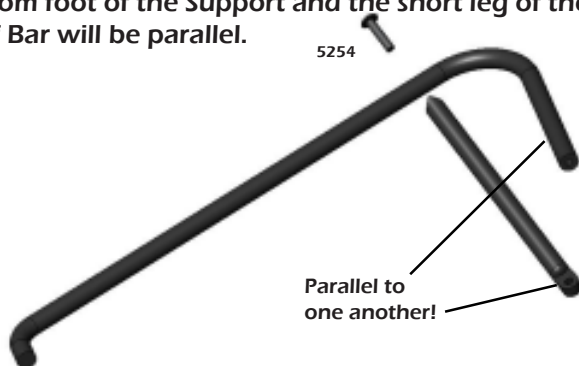

### **STEP #4**

- Mount 3233 Front Bumper using 5278 Screws.
  - Mount the 3241 Wing Slide Bushing to the Cage using 5255 Screws thru the Bushing and Cage and into the 3235 Upper Cage Brace.
  - Use the (2) Long 5279 Hole Head Screws mount the 3235 Upper Cage Braces onto the top of the Main Cage Halfs.
  - Use the remaining (2) Short 5280 Hole Head Screws in the back of the Main Cage Halfs.
- NOTE:** Do NOT tighten all the way down, leave a gap of .100" between the screw head and cage.
- After completing the Body Panel steps, Attach the rear of the Nerf Bar using the 5254 Screw thru the cage as shown. Attach the front of the Nerf Bar and the Nerf Bar Support to the bottom of the "legs" on the Main Cage Half using 5274 Screws.

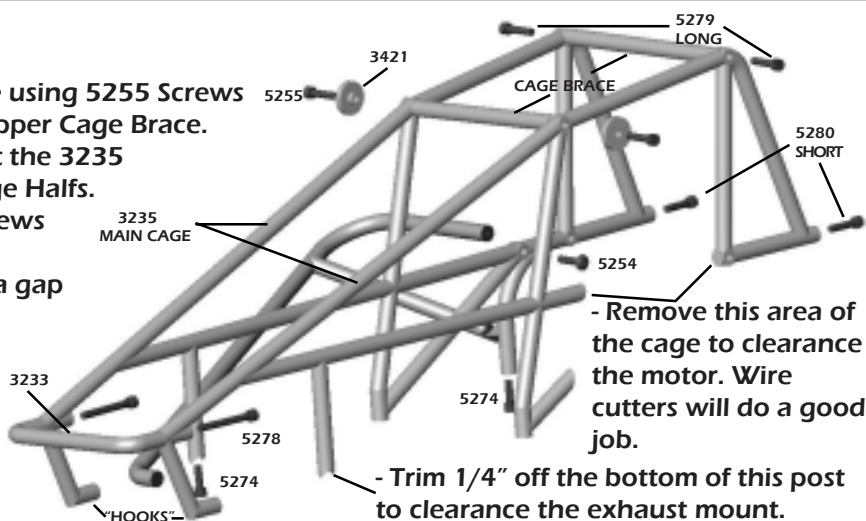

### **CAGE INSTALLATION AND REMOVAL:**

- Place the cage between the front suspension tower with the "HOOKS" slightly further forward than the front edge of the chassis.
- Guide the "HOOKS" into the Front Cage Mount while guiding the Short 5280 Hole Head Screws into the Rear Bulkhead.
- Position the (2) 5274 Screws that will mount the nerf bar to the bottom of the Cage Half into the holes in the Chassis.
- Lock the cage by placing 9036 Clip into the Hole in the Head of the 5280 Screw.

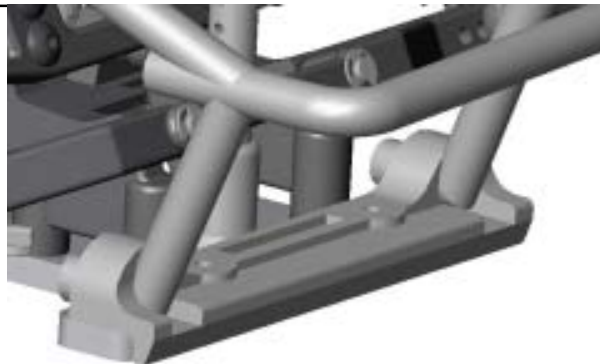

## Body Panel Bag

## Body Panel Prep & Mounting



**- Do these steps BEFORE painting your body panels!!!**

- Cut the 9024 Left Body Panel to fit the Body Template provided.
- Use the Body Template ONLY to cut the front edge of the Right Body Panel.
- Follow the molded lines on the 9029 Eagle Hood and 9026 Tail Tank.
- Additional trimming may be required to clearance suspension movements.

### BODY HOLE NOTES:

HOLE #1: Fit the Side Panels and Hood to the Cage, make a mark where the Body Post meets the Hood.

HOLE #2: Using the Body Template, make a mark where noted on the Template. Use a small screw to mount.

HOLE #3, #4 & #5: Use the provided body line or mark molded into the Body Panel.



## Top Wing

- Assemble the #9021 Wing Kit using the instructions provided inside the wing kit. Mount the wing to the car and it should now look just like the car shown below.



**CONGRATULATIONS!!!** You have now completed the assembly process of your new Custom Works Nitro Enforcer GSX2! In the next section of this manual you will find some basic setup hints and advice. It is important to remember that all tracks and racing surfaces are different. Therefore the suggestions we give you are general in nature and should by no means be treated as the only options.

**MAINTENANCE:**

Occasionally dirt will get into the moving and pivoting locations in your car. It is best to periodically clean your car to keep all the suspension components moving freely. Read the tips below to keep your car running at its best!

- Begin by removing the majority of the dirt using a small brush, toothbrush, or compressed air.
- Compressed air is ok to use, be mindful to not FORCE the dirt into the radio gear, transmission, bearings, or air filter. Typically these items only have dirt on them, hitting the dirt with the compressed air puts dirt ***IN*** these parts!
- Tires, either foam or rubber are best cleaned using water or cleaners like Simple Green (TM). Simple Green also does a great job cleaning car parts as well. Lightly spraying car parts (NOT radio components, transmission, air filter, or bearings) with Simple Green and blowing off with compressed air or wiping the parts using the paint brush is a great way to clean in a hurry.
- Another R/C friendly cleaner is WD-40 (TM). After the car is clean, very lightly spray the car components and bearings (NOT radio components, transmission, or air filter). Use your brush or compressed air to remove the extra WD-40. This will lube your bearings and leave a protective coating on the parts making it easier to remove dirt later.
- Differential Maintenance is needed when the action of the diff feels “notchy”. Usually cleaning the diff parts, re-sand the thrust and diff plates with 400 paper, and lube appropriately will be all that is needed to bring back to new. Ignoring your differential will lead to handling woes and increase transmission temps, which will cause part failure.

**TUNING TIPS:** These are some general guidelines for optimizing handling performance. None of these “tips” are EVER set in stone. On any given day this manual or any chassis engineering book or guru can be proved wrong by the stop watch. A good way to approach chassis set-up is to try one change, practice it, think how the car felt different from before, and compare lap times from the stop watch.....this will never fail.

<b><u>Car Pushes (understeers):</u></b>	<b><u>Car Is Loose (oversteers):</u></b>	<b><u>Car Is Erratic:</u></b>
<ul style="list-style-type: none"> <li>- Decrease Wing Angle</li> <li>- Decrease Spoiler on Wing</li> <li>- Heavier Rear Spring</li> <li>- Softer Front Spring</li> <li>- Use Rear Sway Bar</li> <li>- Try Softer Front Compound Tire</li> <li>- Try Harder Rear Compound Tire</li> <li>- Lower Front Ride Height</li> <li>- Raise Rear Ride Height</li> <li>- Thread Shock Collar UP on Right Front</li> <li>- Thread Shock Collar DOWN on Right Rear</li> <li>- Decrease Rear Toe</li> <li>- Decrease Castor</li> <li>- Add Rear Toe Stagger or Increase the difference</li> </ul>	<ul style="list-style-type: none"> <li>- Increase Wing Angle</li> <li>- Add Spoiler to Wing</li> <li>- Softer Rear Spring</li> <li>- Heavier Front Spring</li> <li>- Use Front Sway Bar</li> <li>- Try Harder Front Compound Tire</li> <li>- Try Softer Rear Compound Tire</li> <li>- Raise Front Ride Height</li> <li>- Lower Rear Ride Height</li> <li>- Thread Shock Collar DOWN on Right Front</li> <li>- Thread Shock Collar UP on Right Rear</li> <li>- Increase Rear Toe</li> <li>- Increase Castor</li> <li>- Decrease Rear Toe Stagger or Decrease the difference</li> </ul>	<ul style="list-style-type: none"> <li>- Bent Suspension Pins: Remove shocks to check free movement.</li> <li>- Bound Ball Joint: Should spin free on balls while mounted to the car.</li> <li>- Bent or Loose Camber Links</li> <li>- Wore out Bearings or Completely Seized Bearings</li> <li>- Chunked Tire: Check to see if Foam or Rubber Tire is still glued to wheel.</li> <li>- Loose Screws: Especially Chassis Screws, add Blue Loctite to prevent.</li> <li>- Shocks: Either Bound-up or Out of Oil. Must swivel freely on mounts.</li> <li>- Foreign Objects: Unlucky Dirt/Stones preventing Suspension or Steering Movement.</li> <li>- Blown Differential</li> <li>- Radio Problem: Bad Servo, Weak Servo Saver Spring, Transmitter Pot blown.</li> </ul>



## **SET-UP GUIDELINES:**

When looking for the "perfect set-up" it is important to remember 2 things...

- 1) Keeping things simple is best.
- 2) As you are making your set-up change, the track is changing too! Ask a local racer what the track usually does from beginning to end, especially day to night.
  - Start your car's ride height with it equal at all four corners to start. Use the shock collars to adjust ride height by measuring the distance under the chassis when the car is sitting on a FLAT & LEVEL surface.
  - Shock collars can only jack weight and adjust the car's handling when the car makes ALL 4 shocks squat when the car is set down. Use the RF shock collar to adjust how the car ENTERS the corner. Use the RR shock collar to adjust how the car exits the corner ON-POWER. Use the LF shock collar to make the car turn in less, and off the corner more.
  - It is best to have a little bit of brake drag when you let off the gas, this will allow for a more controllable car in ALL conditions. Increasing how much the brake drags will make your car turn into the corner harder.

## **SET-UP GLOSSARY:**

**caster:** Angle of the kingpin in relation to a vertical plane as viewed from the side of the car. Increasing the angle will make the car more stable out of the turn and down the straights and increase steering entering a turn. Decreasing the angle will make the car feel more "touchy" at high speeds and help steering while exiting the turn.

**Camber Gain:** Angle of the Camber Link relative to the Suspension Arm. Lowering the camber link on the shock tower OR raising the camber link on the castor block will INCREASE the camber angle of the tire when the suspension is compressed. Raising the camber link on the shock tower OR lowering the camber link on the castor block will DECREASE the camber angle of the tire when the suspension is compressed. There is not a "correct" set-up and once again too much of anything is generally bad. This will help change the "feel" of the car thru the turns.

**Camber Link Length:** Comparing this to the length of the Suspension Arm from each pivot point and keeping the Camber the same, making the link *shorter* will decrease traction for that corner of the car while making it *longer* will increase traction for that corner of the car. Once the camber link is equal to or greater than the Suspension Arm pivots, the gain of traction ends. Also a shorter camber link will increase camber gain and a longer decrease camber gain.

**Shock Angle:** Leaning the shock toward the car is effectively like changing to a *softer* spring. Standing the shock closer to vertical is effectively like changing to a *stiffer* spring. Try when the car is working well and when one spring change is TOO much for your set-up.

**Ride Height:** Check by pushing the chassis down once or twice to simulate bumps on the track. Having the front end *higher* than the rear will make the car increase rear traction especially out of the turn. Having the front end *lower* than the front will make the car increase front traction especially entering the turn. Generally its safe to start the car with the ride heights even.

**Rear Toe-In:** Front edge of car tires point *toward* the chassis as viewed from above the car. Increasing the angle toward the car will increase rear traction while decreasing front traction. Decreasing the angle will do the opposite.

**Rear Toe Stagger:** Difference in the amount of Rear Toe-In among the rear tires. Typically used only on high bite tracks with MORE toe-in on the Left Rear tire than the Right so the rear of the car helps turn the car LEFT under acceleration.

**Wheelbase (Front End):** Wheelbase is the distance between the front and rear axles. Running the entire front end assembly in the forward position makes the wheelbase longer and therefore more stable on long/fast tracks with flowing turns. Running the entire front end assembly in the rear position make the wheelbase shorter and therefore more suitable for short-tracks where you are constantly turning.

**Wheelbase (Rear End):** This adjustment uses the plastic spacers on the kingpin the rear bearing carrier rides on. With the spacers in front of the carrier it will lengthen the wheelbase but will increase steering. If the spacers are behind the carrier it will shorten the wheelbase but increase rear traction. This is completely backwards from how it works for the Front End only because in the rear of the car you have the weight of the motor and the torque it creates. Shortening the wheelbase here makes more of the car hang over the rear tires and promotes more weight transfer.

**Final Drive Chart:** The chart provided below gives you the final drive of the motor to spin the axle 1 revolution. This chart is NOT just the pinion and spur, but has the transmission ratio included as well.

To determine the final drive in your car:

- 1) Divide the Spur Gear by the Pinion Gear, which equals a "Ratio".
- 2) Multiply the "Ratio" by the "Transmission Ratio", which will equal your "Final Drive".

Final Drive Ratio Chart

Transmission Ratio 2.60

Pinion	Spur Gear							
	54	56	58	60	62	64	66	68
12	11.70	12.13	12.57	13.00	13.43	13.87	14.30	14.73
13	10.80	11.20	11.60	12.00	12.40	12.80	13.20	13.60
14	10.03	10.40	10.77	11.14	11.51	11.89	12.26	12.63
15	9.36	9.71	10.05	10.40	10.75	11.09	11.44	11.79
16	8.78	9.10	9.43	9.75	10.08	10.40	10.73	11.05
17	8.26	8.56	8.87	9.18	9.48	9.79	10.09	10.40
18	7.80	8.09	8.38	8.67	8.96	9.24	9.53	9.82
19	7.39	7.66	7.94	8.21	8.48	8.76	9.03	9.31
20	7.02	7.28	7.54	7.80	8.06	8.32	8.58	8.84
21	6.69	6.93	7.18	7.43	7.68	7.92	8.17	8.42
22	6.38	6.62	6.85	7.09	7.33	7.56	7.80	8.04
23	6.10	6.33	6.56	6.78	7.01	7.23	7.46	7.69
24	5.85	6.07	6.28	6.50	6.72	6.93	7.15	7.37
25	5.62	5.82	6.03	6.24	6.45	6.66	6.86	7.07
26	5.40	5.60	5.80	6.00	6.20	6.40	6.60	6.80
27	5.20	5.39	5.59	5.78	5.97	6.16	6.36	6.55
28	5.01	5.20	5.39	5.57	5.76	5.94	6.13	6.31
29	4.84	5.02	5.20	5.38	5.56	5.74	5.92	6.10
30	4.68	4.85	5.03	5.20	5.37	5.55	5.72	5.89
31	4.53	4.70	4.86	5.03	5.20	5.37	5.54	5.70
32	4.39	4.55	4.71	4.88	5.04	5.20	5.36	5.53
33	4.25	4.41	4.57	4.73	4.88	5.04	5.20	5.36
34	4.13	4.28	4.44	4.59	4.74	4.89	5.05	5.20
35	4.01	4.16	4.31	4.46	4.61	4.75	4.90	5.05

