

INTIMIDATOR

G6

INSTRUCTIONS

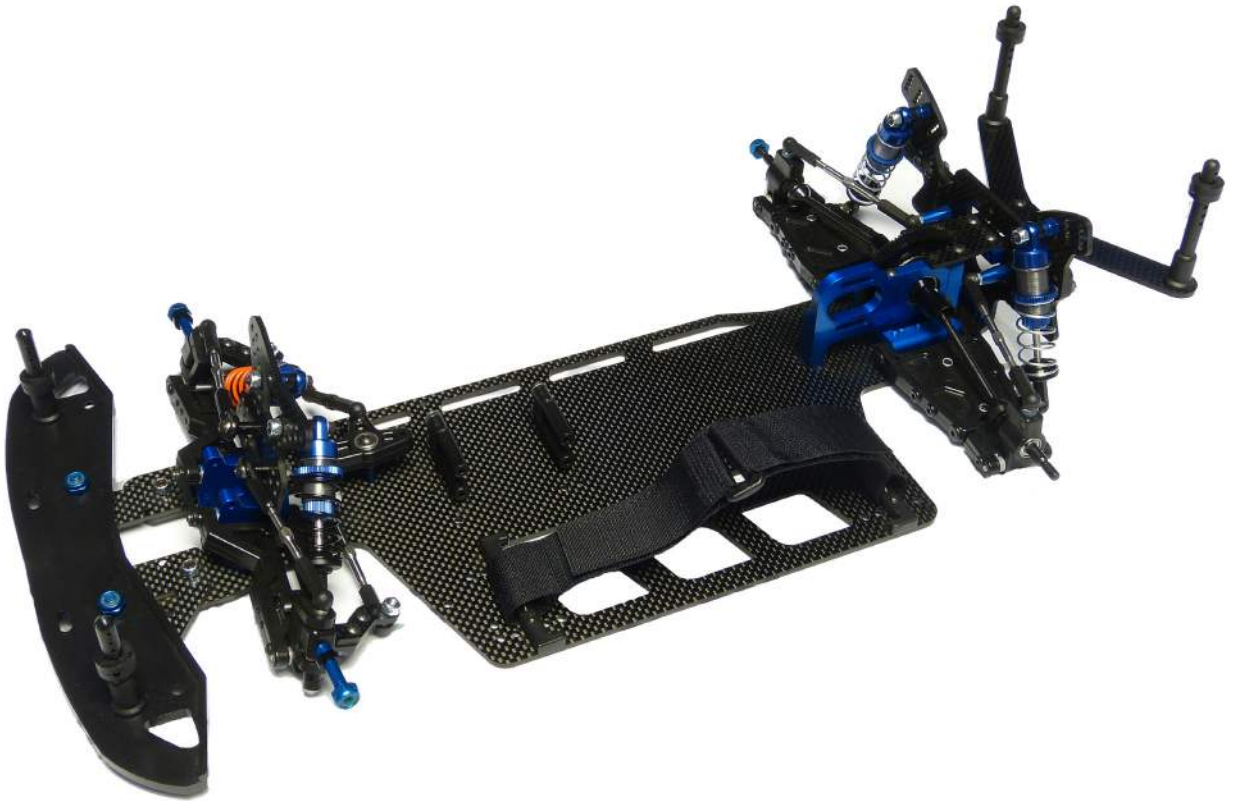

#0915 INTIMIDATOR G6 GEARBOX RACING KIT

Manufactured By:

www.customworksrc.com

CUSTOMWORKS
R/C CARS

760 Crosspoint Drive

Denver, NC 28037

www.CustomWorksRC.com

REQUIRED READING... UNDERSTAND THIS MANUAL!

Thank You and Congratulations on purchasing the **INTIMIDATOR G6 DD!** Within this kit you will find a race winning car with over 28 years worth of **CUSTOM WORKS** design and quality. In order for you to realize this race car's winning potential it is important to follow the written text along with the pictures included. The steps required to build this car are very easy, as long as you read before you build.

The instructional format for building this car is to use the "named" bag titled at the top of each section. Each section will be broken down into "steps" thru the section. The bag containing the chassis holds a variety of unique parts for your kit. Parts and hardware needed to complete each step will be found in the individual "named" bag plus the few unique items from the chassis bag you may need for that particular step. All parts are referred to by their replacement part number in the instructions.

Considering the various dirt or clay surfaces that Dirt Oval cars are raced on today, the Intimidator has been designed to be competitive on high bite and well groomed clay tracks with foam racing tires. The instructions will build the kit using the most verastale set-up Custom Works has found in testing on different types of tracks, however there are various other suspension configurations available to you that you may find more suitable for your local track. For updates and more proven set-ups login to CustomWorksRC.com or check out our video's on our YouTube channel.

BUILDING TIPS...

-Parts are made with tight tolerance and held to the side of a "snug" fit as wear is expected over time. Try as we may, occasionally a burr may remain in a part and fit more tightly than desired. It is ok to use 400 Grit Sandpaper or a .125" drill to SLOWLY relieve a part from time to time. Suspension components should always pivot and swivel freely but not sloppily.

-Using some type of thread locking fluid is suggested for all parts where metal screws thread into other metal parts. We suggest using a lite setting strength thread lock for the reason you may want to take the screw out one day. Remember it only takes a very small amount to secure the screw.

-Do **NOT** use power screwdrivers to drive screws into parts. The fast rotation speed can melt and strip plastic parts or cross-thread into the aluminum parts.

-Lightly sand the edges of graphite pieces using a medium grade sandpaper to avoid splinters. Run a thin bead of Super Glue around the edges to give pieces greater durability.

SUGGESTED TOOLS

400 Grit Sandpaper

Hobby Scissors

Small Needle Nose Pliers

Wire Cutters

X-Acto Knife

















Phillips Head Screw Driver

Blue Loctite

3/16" Wrench

HARDWARE GUIDE

-Use the hardware below to help identify the appropriate screw to use throughout the manual.

	1/4"	3/8"	1/2"	5/8"	3/4"	7/8"	1"
BUTTON HEAD	 5252	 5253	 5254	 5255	 5257		 5259
FLAT HEAD	 5262	 5263	 5264	 5265			 5268
SOCKET HEAD		 5273	 5274	 5275		 5277	 5278

Front Suspension

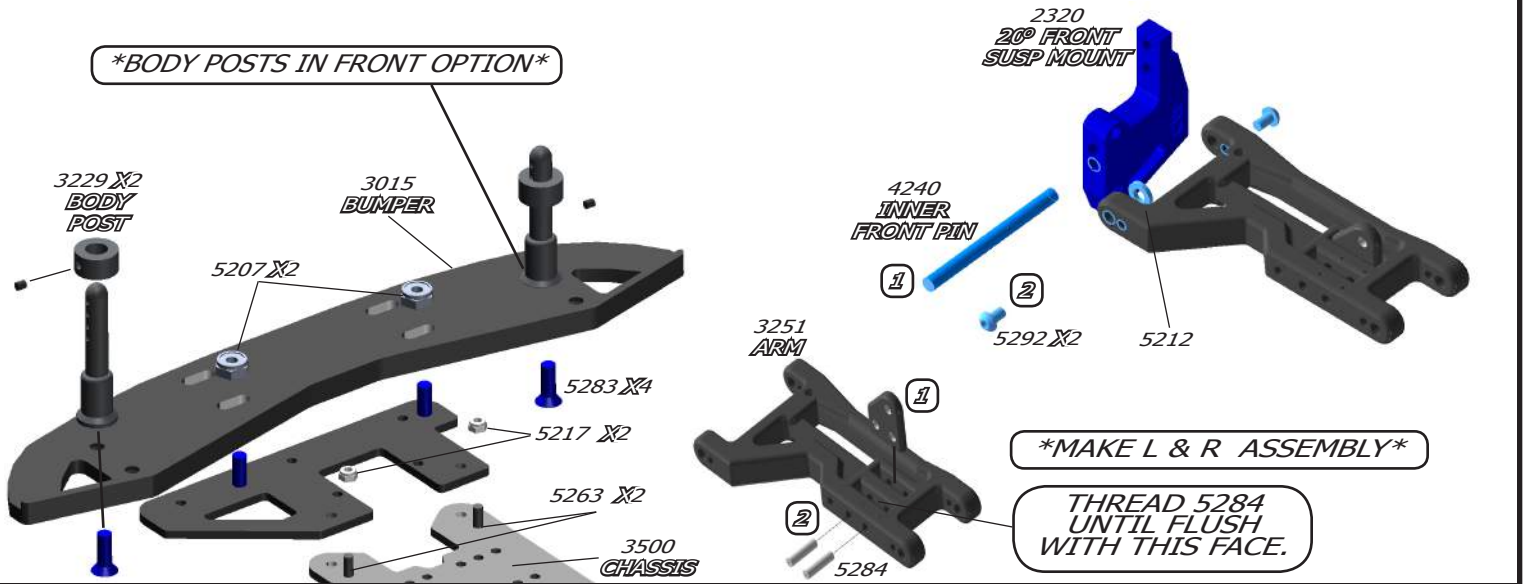

Front Suspension

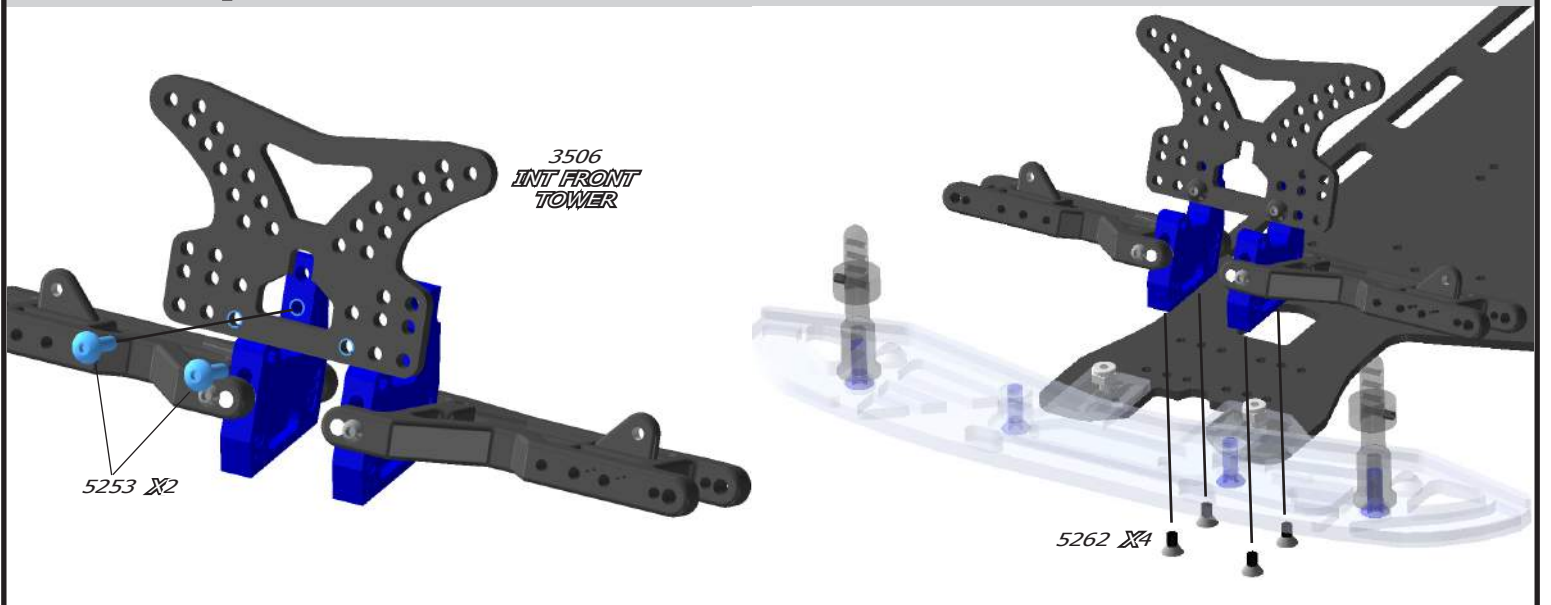

Steering Components: Spindle & Castor Blocks

- HELP ALIGN AXLE AND SPINDLE HOLES USING A .125" DRILL BIT BY HAND ONLY.

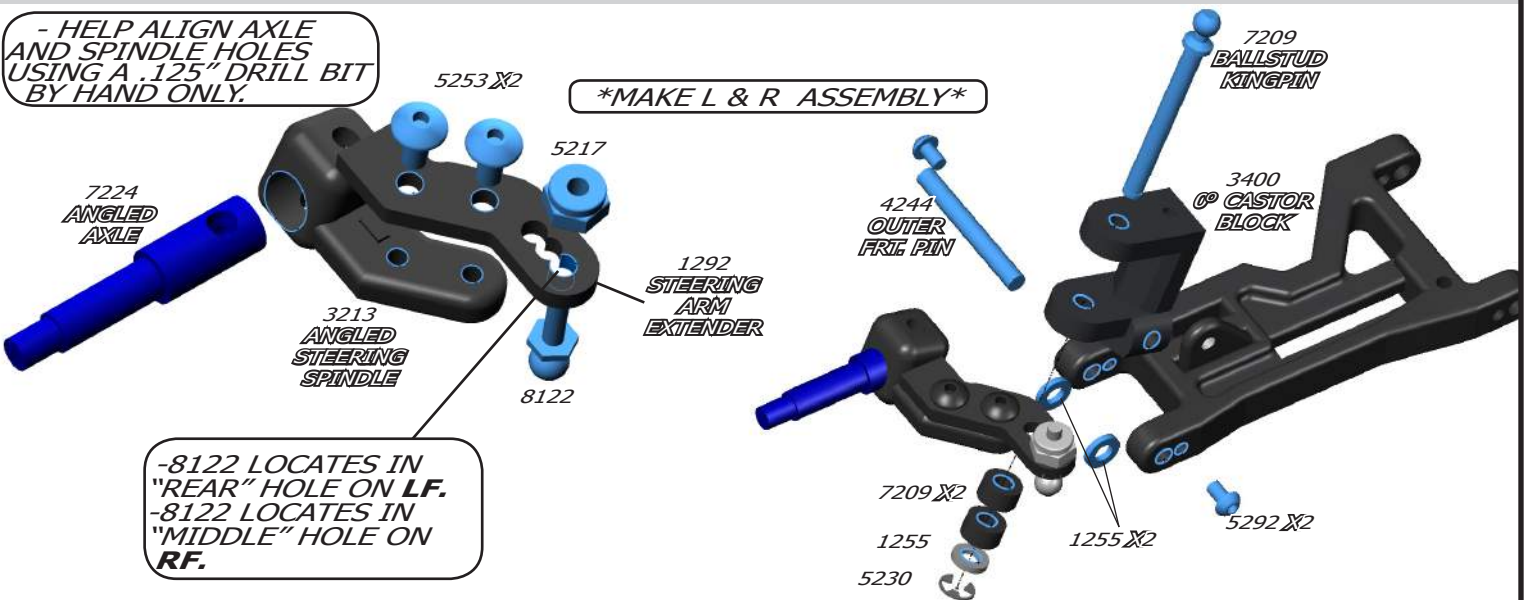

Steering Components: Linkages 1

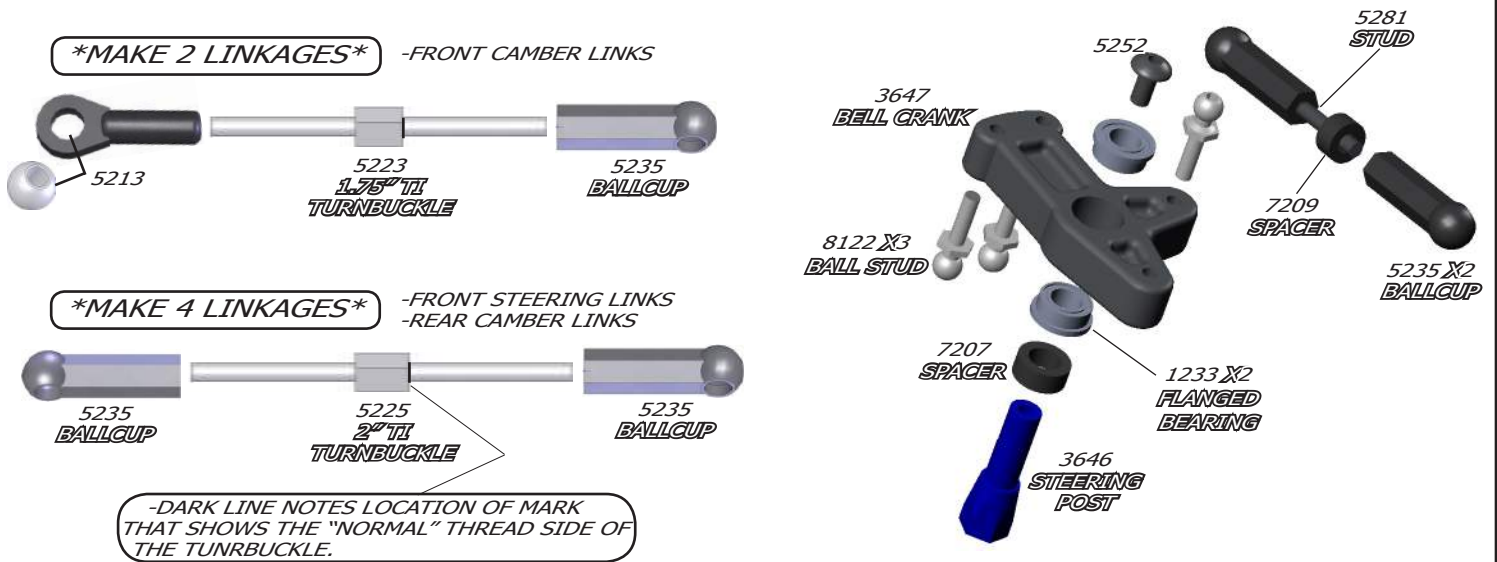

Steering Components: Linkages 2

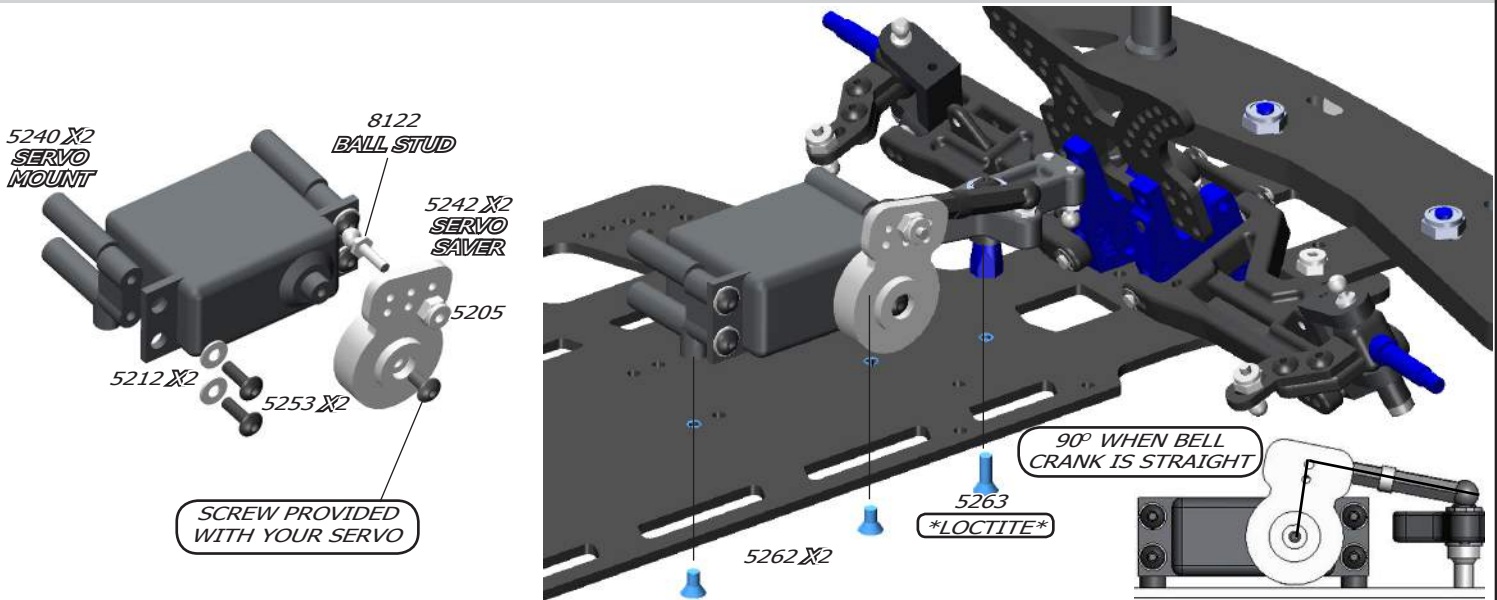

Steering Components: Linkages 3

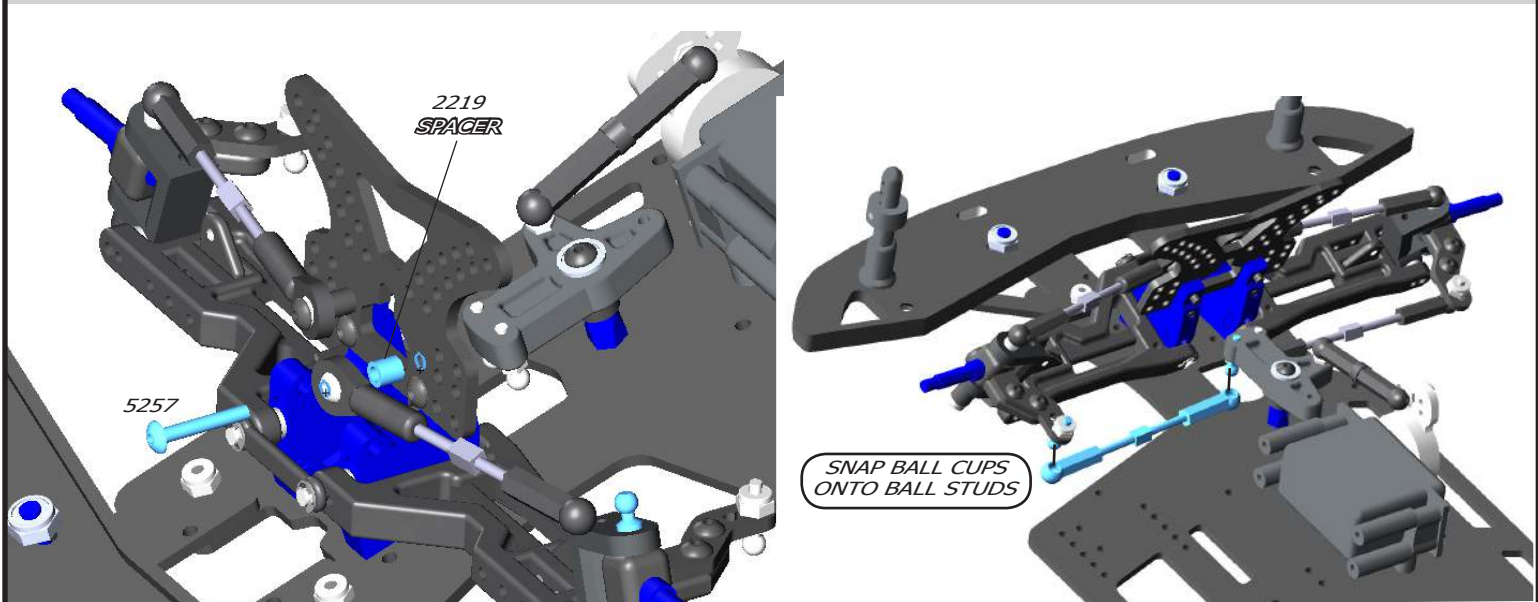

Rear Suspension: Tower & Suspension Arm Assembly

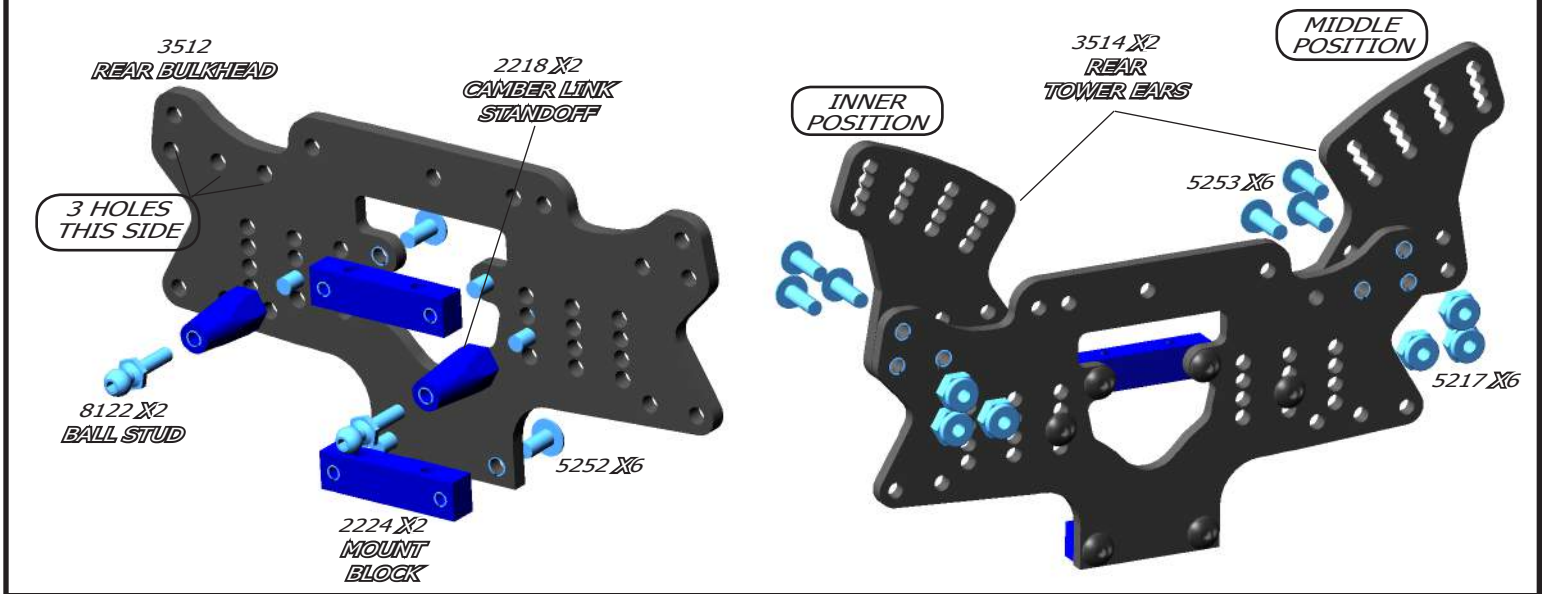

Rear Suspension: Chassis Locations

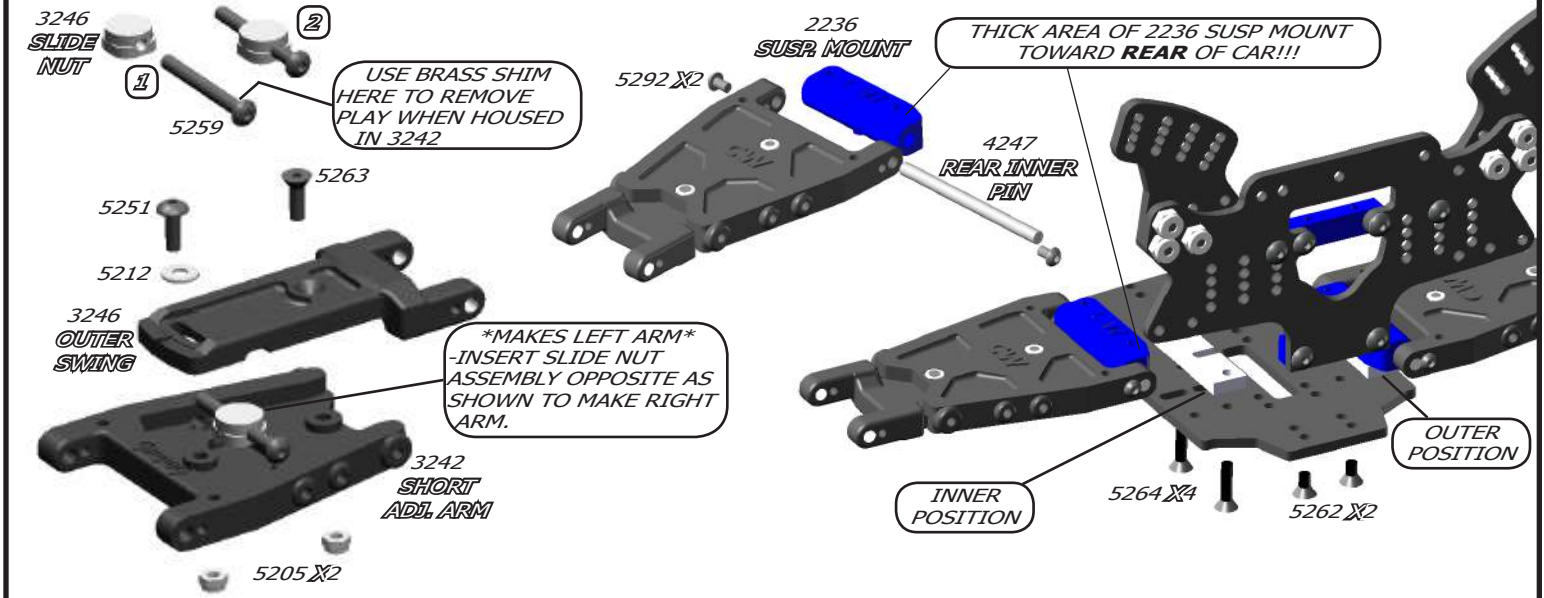

CVD & Drive Assembly: Bearing Carrier & CVD

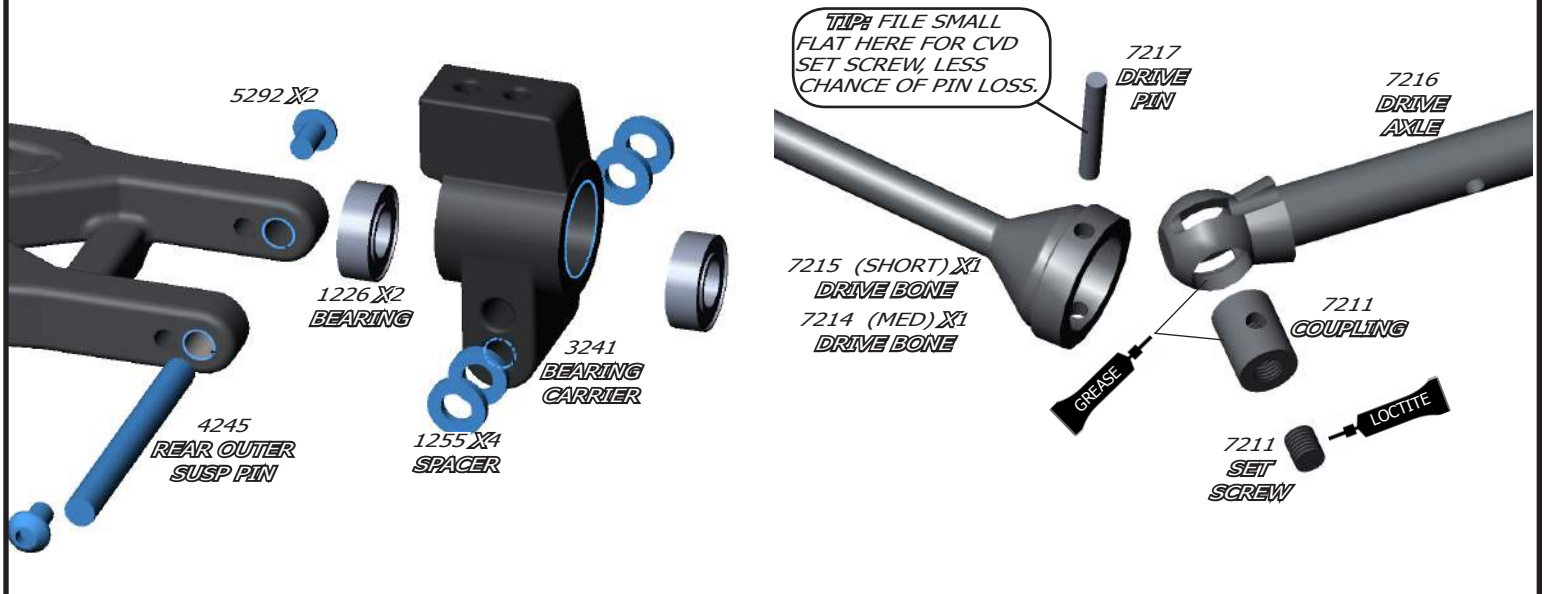

CVD & Drive Assembly: Installation

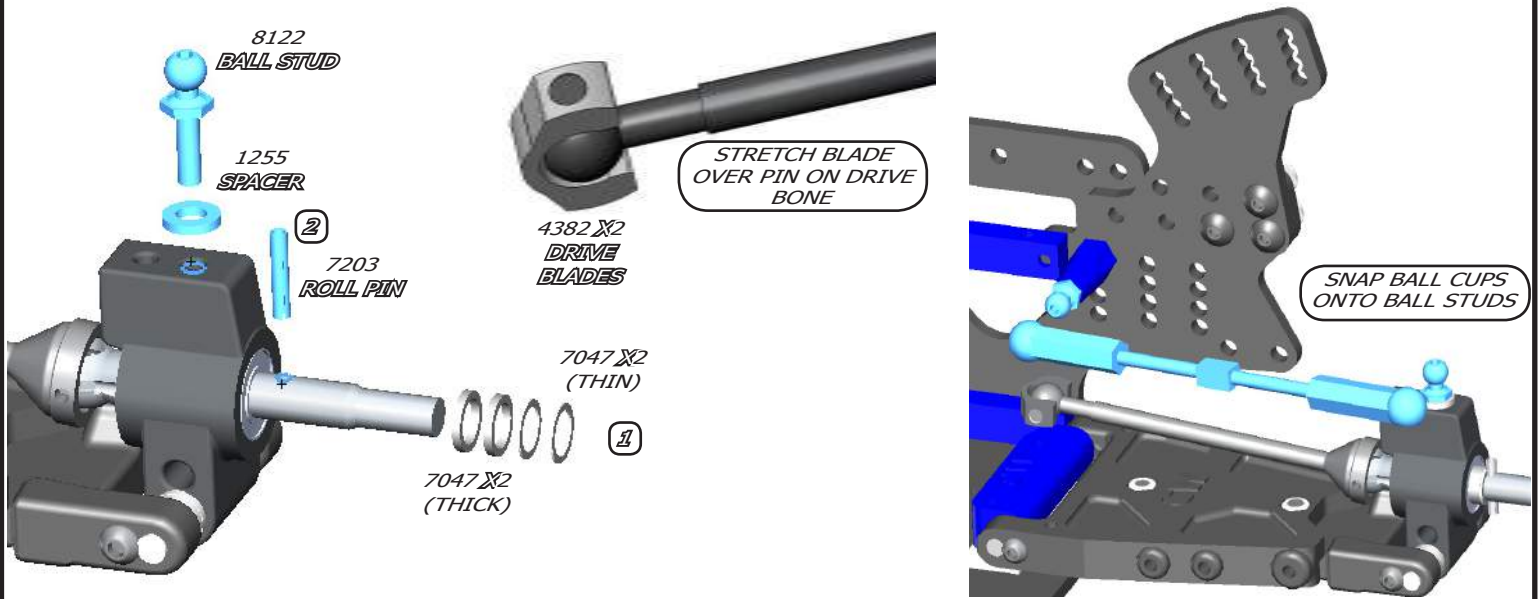

Gear Box Diff Assembly

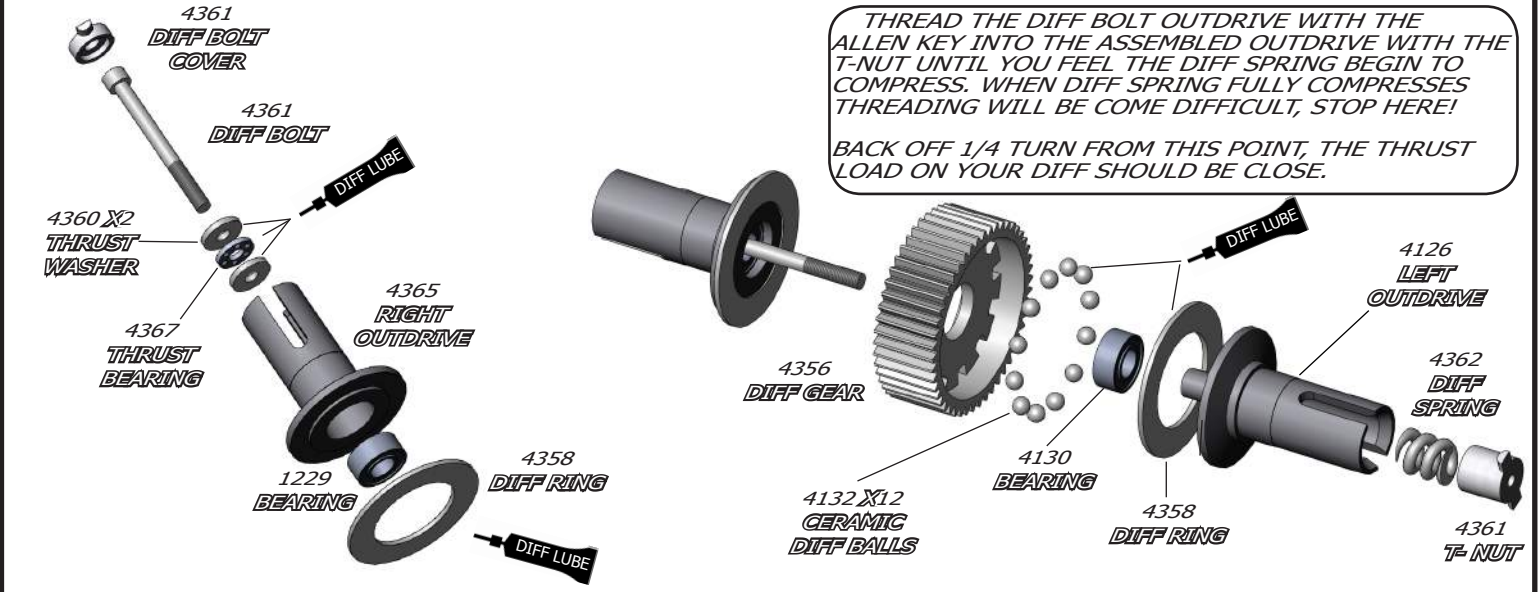

Transmission

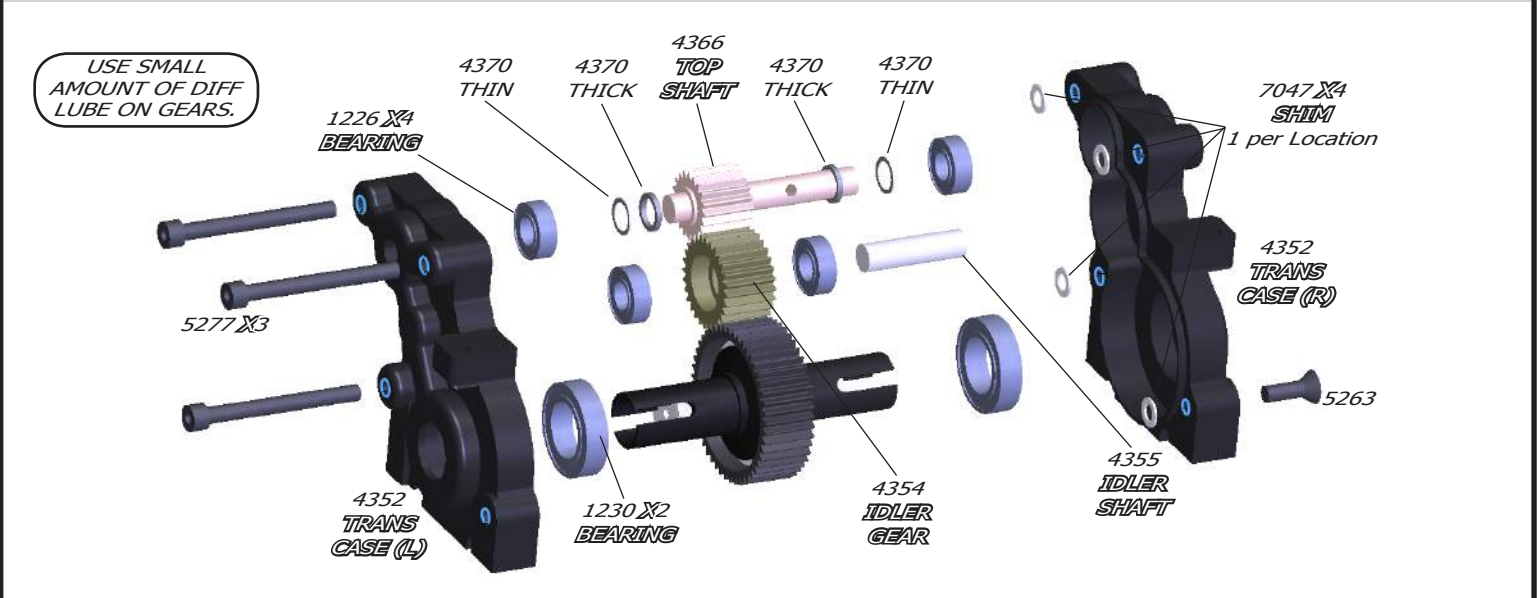

Transmission Mount

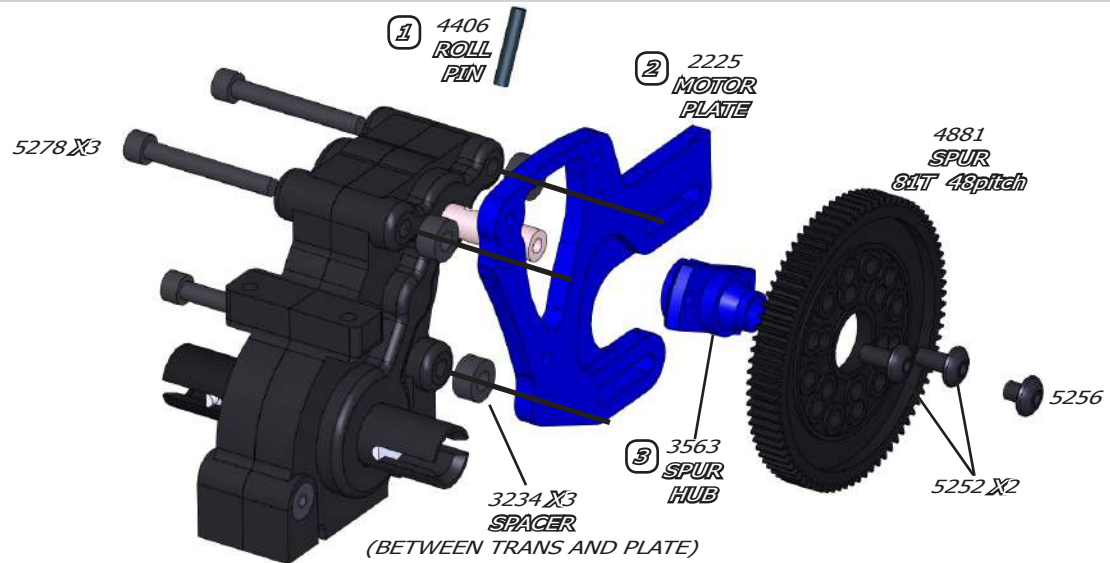

Transmission Mount

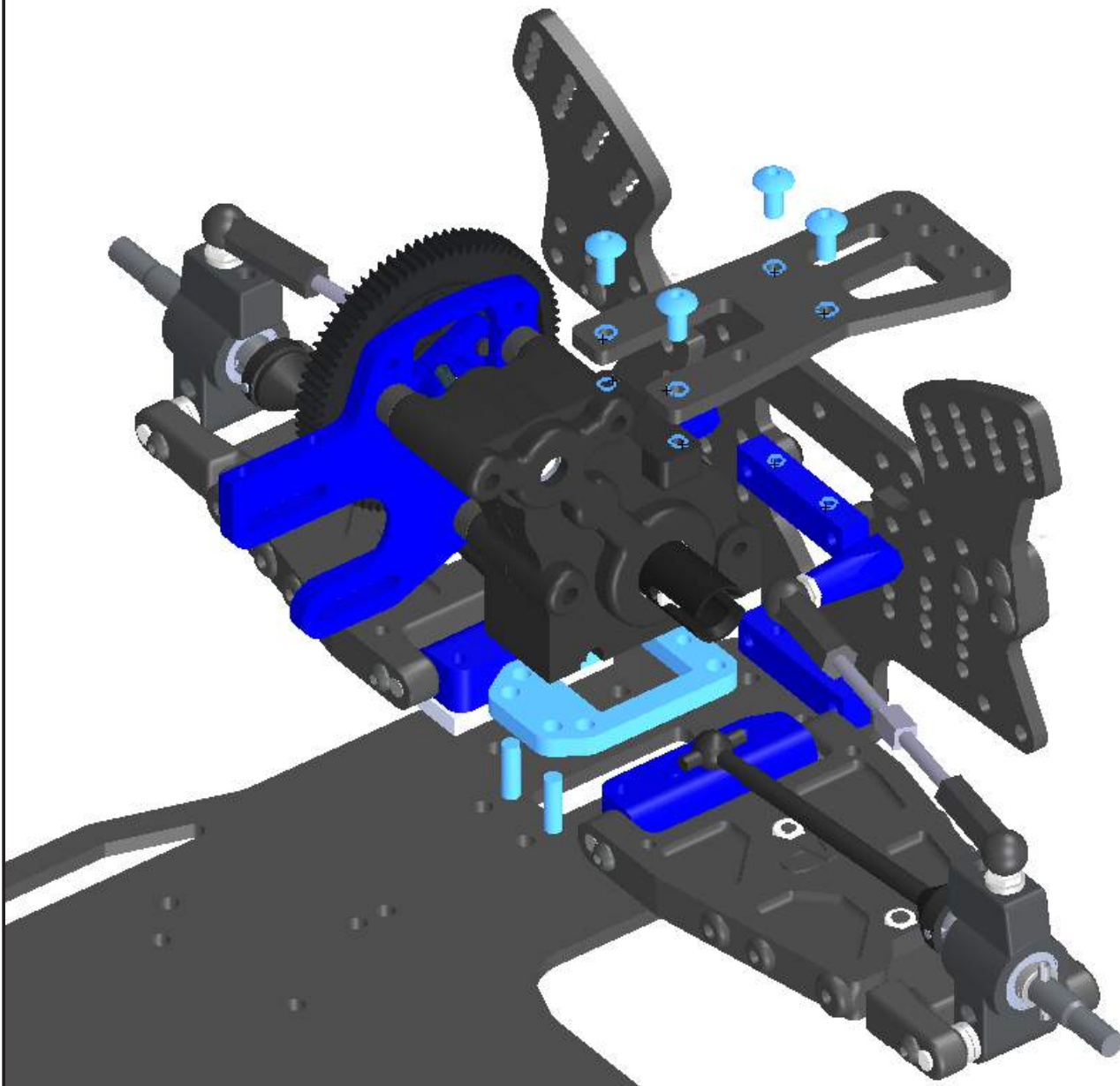

Transmission Mount

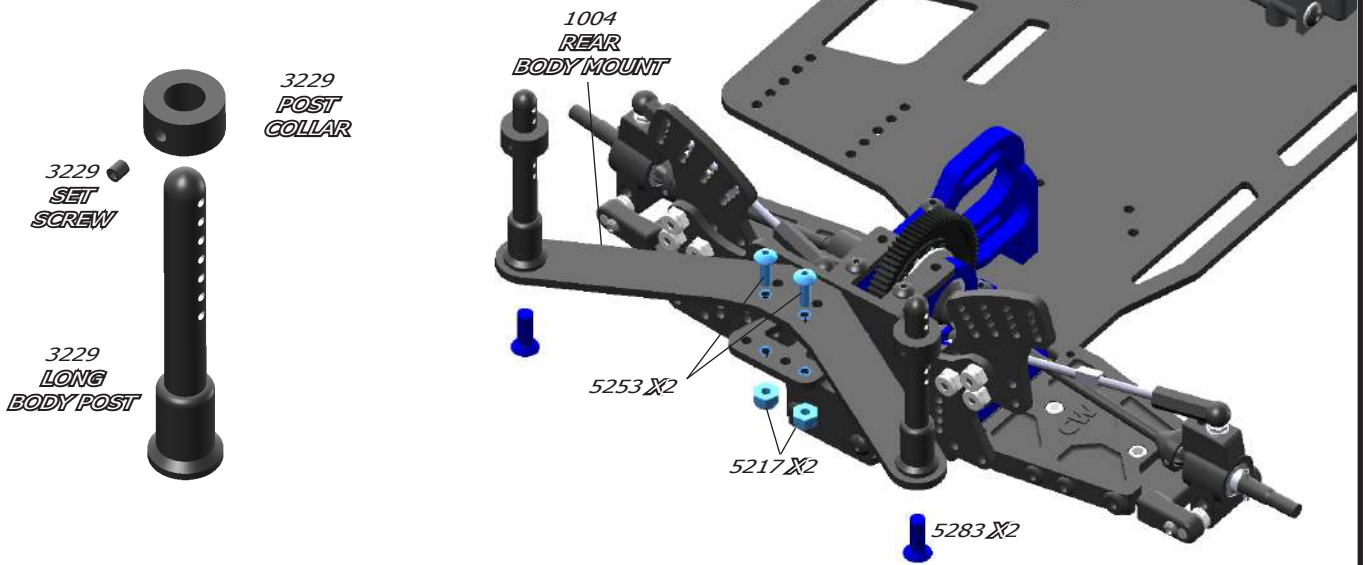

Shocks: Assembly

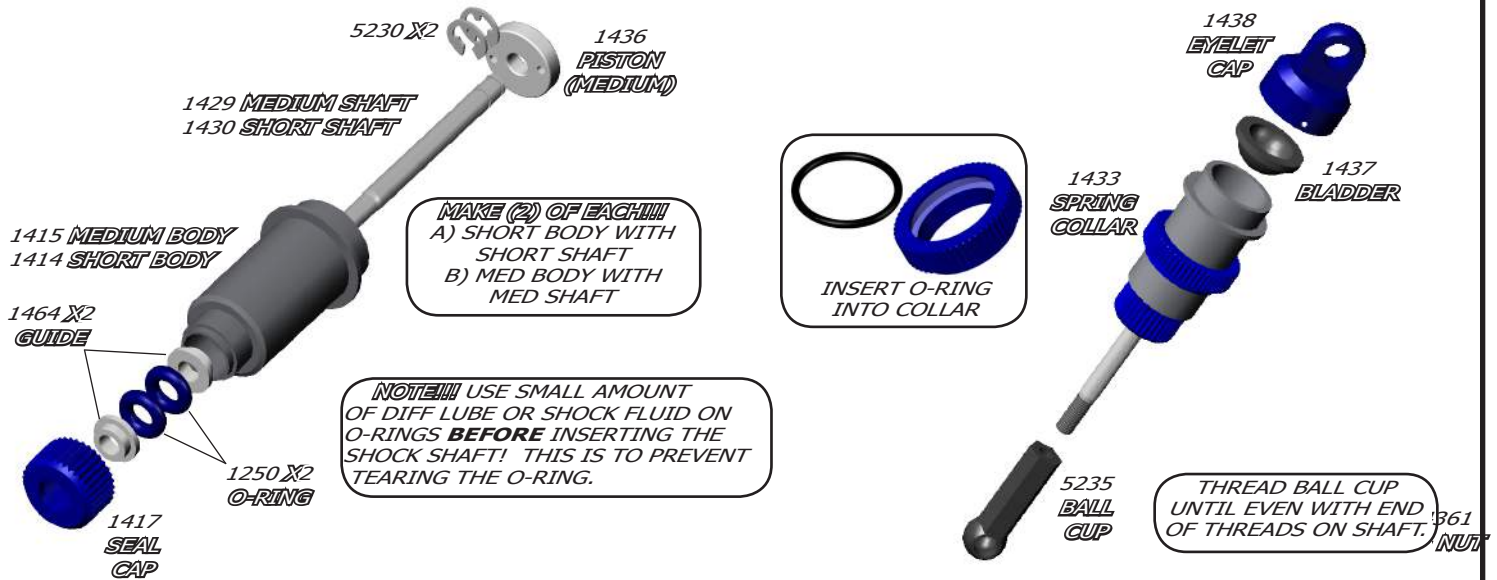

Shocks: Fluid Filling

1) Holding the shock upright, fill with oil until just under the top of the body.



2) Slowly move the shaft up and down several times to allow air bubbles to escape to the top.



3) Refill shock as instructed in Step 1 if need be.



4) Place Bladder onto top of shock, small amount of oil should displace.

Thread the Eyelet Cap assembly onto the Shock Body until it is hand tight.

Oil should seep out of the bleed hole in the Eyelet Cap.



5) Move the shock shaft in and out a few times and then push it all the way in. It should be easy to push the shaft in until the ball cup is within 1/16" of hitting the body.



6) Then the shaft should push itself out to its full length slowly.



7) If the shock does not push out this far there is not enough oil in it. Add just a little oil and try steps 5-6 again.



8) If the shock rebounds too fast, or you cannot push the shaft in until the ball cup gets close to the body, there is too much oil. Simply remove the Eyelet Cap and retighten the cap, typically this will allow just enough oil to escape to be successful without under-filling the shock.



Spring/Shock Locations:
RF: Orange on Short Shock
LF: Black on Short Shock
Rear: Chrome on Med Shocks

Shocks: Mounting

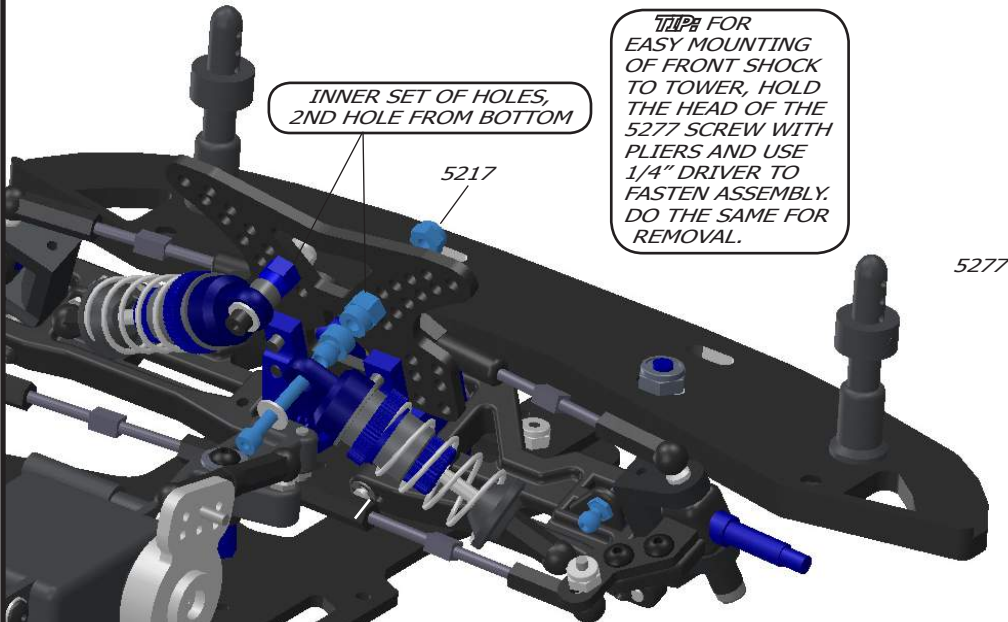

TIP: FOR EASY MOUNTING OF FRONT SHOCK TO TOWER, HOLD THE HEAD OF THE 5277 SCREW WITH PLIERS AND USE 1/4" DRIVER TO FASTEN ASSEMBLY. DO THE SAME FOR REMOVAL.

Spring/Shock Locations:
 RF: Orange on Short Shock
 LF: Black on Short Shock
 Rear: Chrome on Med Shocks

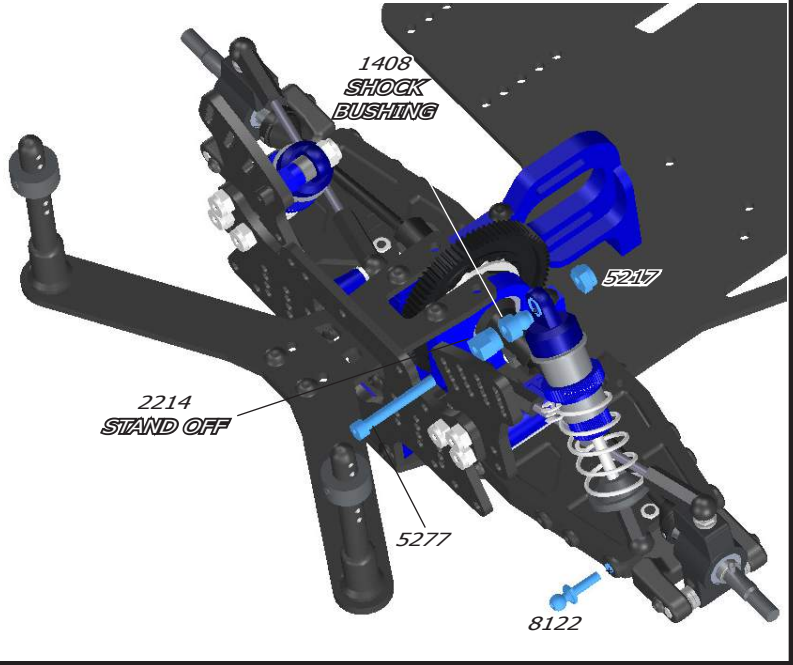
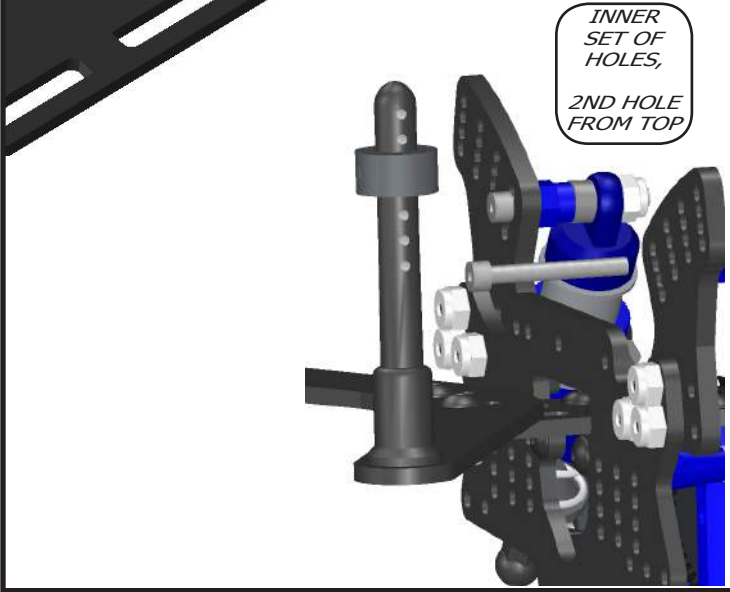
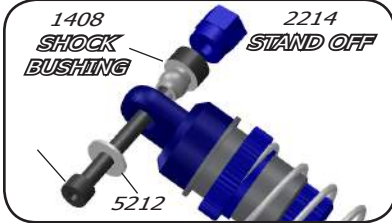

Battery Mounts

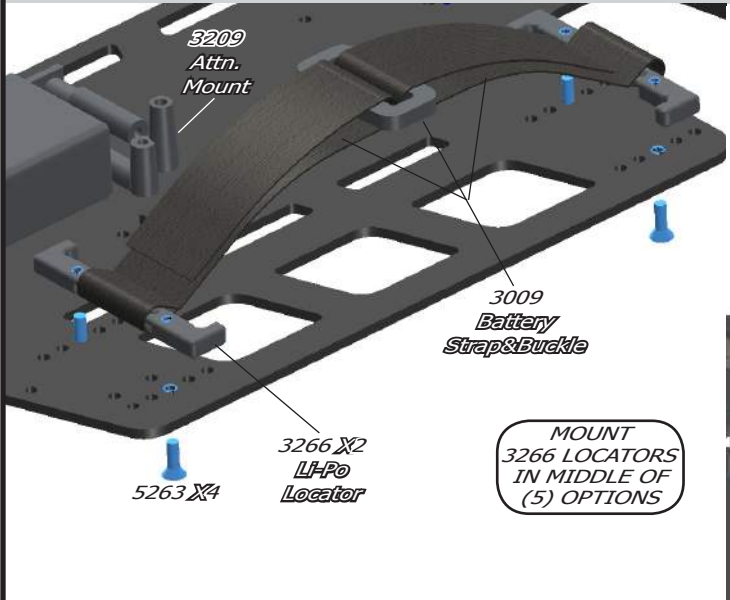

MOUNT 3266 LOCATORS IN MIDDLE OF (5) OPTIONS

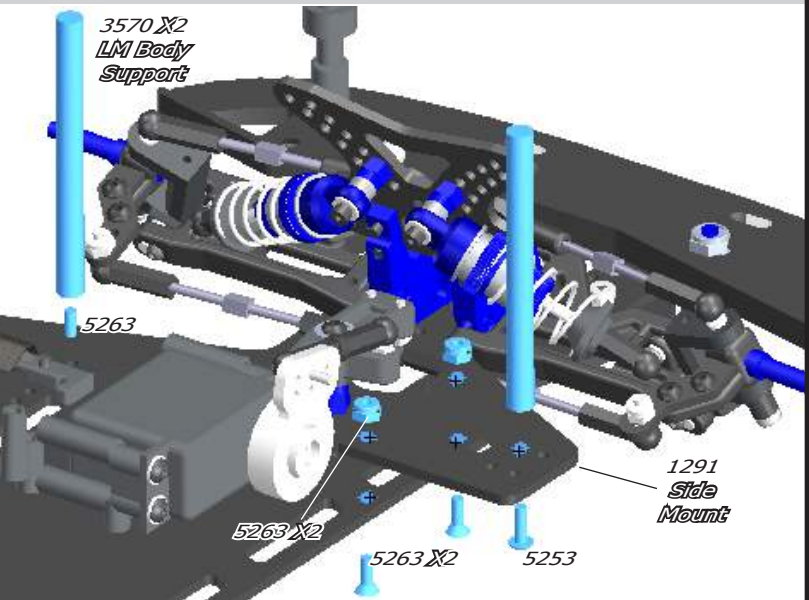

CONGRATULATIONS!!!! You have now completed the assembly process of your new CustomWorks Intimidator. In the next section of this manual you will find some basic setup hints and advice. It is important to remember that all tracks and racing surfaces are different. Therefore the suggestions we give you are general in nature and should by no means be treated as the only options.

MAINTNANCE: Occasionally dirt will get into the moving and pivoting locations in your car. It is best to periodically clean your car during the race day to keep all the suspension components moving freely. Read the tips below to keep your car running at its best!

- Begin by removing the majority of the dirt using a small brush, toothbrush, or compressed air.
- Compressed air is ok to use, be mindful to not FORCE the dirt into the radio gear, transmission or bearings. Typically these items only have dirt on them, hitting the dirt with compressed air puts dirt IN these parts!
- Tires, either foam or rubber are best cleaned using water or cleaners like Simple Green (TM). Simple Green also does a great job of cleaning car parts as well. Lightly spraying car parts (NOT radio components transmission, bearings) with Simple Green and blowing off with compressed air or wiping the parts using a paint brush is a great way to clean in hurry.
- Another R/C friendly cleaner is WD-40 (TM). After the car is clean, very lightly spray the car components and bearings (NOT radio components transmission). Use your brush or compressed air to remove the extra WD-40. This will lube your bearings and leave a protective coating on the parts making it easier to remove dirt later. Other products related to R/C and motorcross sell spray coatings that accomplish the same or better protection.
- Differential Maintenance is needed when the action of the diff feels "notchy". This occurs when the car is loose of the corner, spinning the LR tire extremely and/or when there is more motor in the car than necessary. Usually cleaning the diff parts, re-sand the thrust and diff plates with 400 grit paper, and lube appropriately will be all that is needed to bring back to new. Ignoring your diff will lead to handling woes and increased trans temps, which will cause part failure.

TUNING TIPS: In this manual are some general guidelines for optimizing handling performance. Be SURE to check out the CustomWorks RC channel on YouTube for more individualized explanation of the many tuning features of your new car. None of these "tips" are EVER set in stone. On any given day this manual or any chassis engineering book or guru can be proved wrong by the stop watch. A good way to approach chassis set-up is to try one change, practice it, think how the car felt different from before, and compare lap times from the stop watch.....this will never fail.

<u>Car Pushes (understeers):</u>	<u>Car Is Loose (oversteers):</u>	<u>Car Is Erratic:</u>
<ul style="list-style-type: none"> - Decrease Wing Angle - Decrease Spoiler on Wing - Heavier Rear Spring - Softer Front Spring - Use Rear Sway Bar - Try Softer Front Compound Tire - Try Harder Rear Compound Tire - Lower Front Ride Height - Raise Rear Ride Height - Thread Shock Collar UP on Right Front - Thread Shock Collar DOWN on Right Rear - Decrease Rear Toe - Decrease Castor - Add Rear Toe Stagger or Increase the difference 	<ul style="list-style-type: none"> - Increase Wing Angle - Add Spoiler to Wing - Softer Rear Spring - Heavier Front Spring - Use Front Sway Bar - Try Harder Front Compound Tire - Try Softer Rear Compound Tire - Raise Front Ride Height - Lower Rear Ride Height - Thread Shock Collar DOWN on Right Front - Thread Shock Collar UP on Right Rear - Increase Rear Toe - Increase Castor - Decrease Rear Toe Stagger or Decrease the difference 	<ul style="list-style-type: none"> - Bent Suspension Pins: Remove shocks to check free movement. - Bound Ball Joint: Should spin free on balls while mounted to the car. - Bent or Loose Camber Links - Wore out Bearings or Completely Seized Bearings - Chunked Tire: Check to see if Foam or Rubber Tire is still glued to wheel. - Loose Screws: Especially Chassis Screws, add Blue Loctite to prevent. - Shocks: Either Bound-up or Out of Oil. Must swivel freely on mounts. - Foreign Objects: Unlucky Dirt/Stones preventing Suspension or Steering Movement. - Blown Differential - Radio Problem: Bad Servo, Weak Servo Saver Spring, Transmitter Pot blown.

SETUP GUIDELINES:

When looking for the "perfect set-up" it is important to remember 2 things...

1) Keeping things simple is best.

2) As you are making your set-up change, the track is changing too! Ask a local racer what the track usually does from beginning to end, especially day to night.

- Start your car's ride height with it equal at all four corners to start. Use the shock collars to adjust ride height by measuring the distance under the chassis when the car is sitting on a FLAT & LEVEL surface. With foam tires in the 2.6" range, .600" to the top of the chassis (1/2" under the chassis) is a good measurement to start with.

- Shock collars can only jack weight and adjust the car's handling when the car makes ALL 4 shocks squat when the car is set down. Use the RF shock collar to adjust how the car ENTERS the corner. Use the RR shock collar to adjust how the car exits the corner ON-POWER. Use the LF shock collar to make the car turn in less, and off the corner more.

- It is best to have a little bit of brake drag when you let off the gas, this will allow for a more controllable car in ALL conditions. Increasing how much the brake drags will make your car turn into the corner harder but can make the car also much more loose to drive into the corner. With most speed controls today a drag brake strength of 10-20% is a good range to work with.

SET-UP GLOSSARY:

Caster: Angle of the kingpin in relation to a vertical plane as viewed from the side of the car.

Increasing the angle will make the car more stable out of the turn and down the straights and increase steering entering a turn. Decreasing the angle will make the car feel more "touchy" at high speeds and help steering while exiting the turn.

Camber Gain: Angle of the Camber Link relative to the Suspension Arm. Lowering the camber link on the shock tower OR raising the camber link on the castor block will INCREASE the camber angle of the tire when the suspension is compressed. Raising the camber link on the shock tower OR lowering the camber link on the castor block will DECREASE the camber angle of the tire when the suspension is compressed. There is not a "correct" set-up and once again too much of anything is generally bad. This will help change the "feel" of the car thru the turns.

Camber Link Length: Comparing this to the length of the Suspension Arm from each pivot point and keeping the Camber the same, making the link shorter will decrease traction for that corner of the car while making it longer will increase traction for that corner of the car. Once the camber link is equal to or greater than the Suspension Arm pivots, the gain of traction ends. Also a shorter camber link will increase camber gain and a longer decrease camber gain.

Shock Angle: Leaning the shock toward the car is effectively like changing to a softer spring.

Standing the shock closer to vertical is effectively like changing to a stiffer spring. Try when the car is working well and when one spring change is TOO much for your set-up.

Ride Height: Check by pushing the chassis down once or twice to simulate bumps on the track.

Having the front end higher than the rear will make the car increase rear traction especially out of the turn. Having the front end lower than the front will make the car increase front traction especially entering the turn. Generally its safe to start the car with the ride heights even.

Rear Toe-In: Front edge of car tires point toward the chassis as viewed from above the car.

Increasing the angle toward the car will increase rear traction while decreasing front traction.

Decreasing the angle will do the opposite.

Rear Toe Stagger: Difference in the amount of Rear Toe-In among the rear tires. Typically used only on high bite tracks with MORE toe-in on the Left Rear tire than the Right so the rear of the car helps turn the car LEFT under acceleration.

Wheelbase (Front End): Wheelbase is the distance between the front and rear axles. Running the entire front end assembly in the forward position makes the wheelbase longer and therefore more stable on long/fast tracks with flowing turns. Running the entire front end assembly in the rear position make the wheelbase shorter and therefore more suitable for short-tracks where you are constantly turning.

Wheelbase (Rear End): This adjustment uses the plastic spacers on the kingpin the rear bearing carrier rides on. With the spacers in front of the carrier it will lengthen the wheelbase but will increase steering. If the spacers are behind the carrier it will shorten the wheelbase but increase rear traction. This is completely backwards from how it works for the Front End only because in the rear of the car you have the weight of the motor and the torque it creates. Shortening the wheelbase here makes more of the car hang over the rear tires and promotes more weight transfer.

Final Drive Chart: The chart provided below gives you the final drive of the motor to spin the axle 1 revolution. This chart is NOT just the pinion and spur, but has the transmission ratio included as well.

- To determine the final drive in your car:

- 1) Divide the Spur Gear by the Pinion Gear, which equals a "Ratio".
- 2) Multiply the "Ratio" by the "Transmission Ratio" which will equal your "Final Drive".

Transmission Ratio = 2.4 for this car.

- Gearing choice can vary greatly depending on track size, surface type, amount of traction, you motor and driving style. For starters consult your local hobby dealer or fellow racer at your local track for the ideal gear choice for your application.

64 Pitch Pinion	71	74	77	80	83	86	89	92	95	98
16	11.70	12.15	12.75	13.35	13.95	14.40	14.80	15.00	15.00	15.00
17	11.01	11.44	12.00	12.47	13.13	13.58	14.12	14.68		
18	10.40	10.80	11.33	11.73	12.40	12.80	13.33	13.87		
19	9.88	10.33	10.74	11.32	11.71	12.18	12.68	13.14		
20	9.36	9.72	10.30	10.58	11.16	11.53	12.00	12.48		
21	8.91	9.26	9.71	10.34	10.83	11.60	11.43	11.80		
22	8.51	8.84	9.27	9.80	10.15	10.47	10.90	11.26		
23	8.14	8.45	8.87	9.18	9.70	10.00	10.43	10.88		
24	7.80	8.10	8.50	8.80	9.30	9.60	10.00	10.40		
25	7.48	7.75	8.15	8.45	8.90	9.20	9.60	9.98		
26	7.18	7.44	7.80	8.12	8.58	8.96	9.33	9.68		
27	6.90	7.15	7.58	7.82	8.27	8.53	8.90	9.24		
28	6.65	6.84	7.20	7.58	7.97	8.23	8.57	8.91		
29	6.44	6.70	7.05	7.28	7.70	7.84	8.28	8.51		
30	6.24	6.48	6.80	7.04	7.44	7.68	8.00	8.32		
31	6.04	6.27	6.58	6.81	7.20	7.43	7.74	8.05		
32	5.85	6.06	6.38	6.60	6.98	7.20	7.50	7.80		
33	5.67	5.86	6.18	6.40	6.76	6.98	7.27	7.58		
34	5.51	5.72	6.00	6.21	6.58	6.78	7.09	7.34		
35	5.35	5.55	5.83	6.03	6.38	6.58	6.85	7.13		
36	5.20	5.40	5.67	5.87	6.20	6.40	6.67	6.93		
37	5.06	5.25	5.51	5.71	6.03	6.23	6.49	6.75		
38	4.90	5.12	5.37	5.58	5.87	6.08	6.32	6.57		
39	4.80	4.98	5.23	5.42	5.72	5.91	6.15	6.40		
40	4.68	4.86	5.10	5.28	5.58	5.76	6.00	6.24		
41	4.57	4.74	4.98	5.15	5.44	5.62	5.85	6.09		
42	4.46	4.63	4.86	5.03	5.31	5.49	5.71	5.94		
43	4.35	4.52	4.74	4.91	5.19	5.36	5.58	5.80		
44	4.25	4.42	4.64	4.80	5.07	5.24	5.45	5.67		
45	4.16	4.32	4.53	4.69	4.96	5.12	5.33	5.55		
46	4.07	4.23	4.43	4.59	4.85	5.01	5.22	5.43		
47	3.98	4.14	4.34	4.49	4.75	4.90	5.11	5.31		

48 Pitch Pinion	66	68	70	72	75	78	81	84
12	13.20	13.60	14.00	14.40	15.00	15.60	16.20	16.80
13	12.18	12.55	12.90	13.29	13.85	14.40	14.95	15.51
14	11.31	11.66	12.00	12.34	12.86	13.37	13.88	14.40
15	10.56	10.88	11.20	11.52	12.00	12.48	12.96	13.44
16	9.90	10.20	10.50	10.80	11.25	11.70	12.15	12.60
17	9.32	9.60	9.88	10.16	10.59	11.01	11.44	11.86
18	8.80	9.07	9.33	9.60	10.00	10.40	10.80	11.20
19	8.34	8.59	8.84	9.09	9.47	9.85	10.23	10.61
20	7.92	8.16	8.40	8.64	9.00	9.36	9.72	10.08
21	7.54	7.77	8.00	8.23	8.57	8.91	9.25	9.60
22	7.20	7.42	7.64	7.85	8.18	8.51	8.84	9.16
23	6.89	7.10	7.30	7.51	7.83	8.14	8.45	8.77
24	6.60	6.80	7.00	7.20	7.50	7.80	8.10	8.40
25	6.34	6.53	6.72	6.91	7.20	7.49	7.76	8.06
26	6.09	6.26	6.45	6.65	6.92	7.20	7.48	7.75
27	5.87	6.04	6.22	6.40	6.67	6.93	7.20	7.47
28	5.66	5.83	6.00	6.17	6.43	6.69	6.94	7.20
29	5.46	5.63	5.79	5.95	6.21	6.46	6.70	6.95
30	5.28	5.44	5.60	5.76	6.00	6.24	6.48	6.72
31	5.11	5.26	5.42	5.57	5.81	6.04	6.27	6.50
32	4.95	5.10	5.25	5.40	5.63	5.85	6.06	6.26
33	4.80	4.95	5.09	5.24	5.46	5.67	5.89	6.11
34	4.66	4.80	4.94	5.08	5.29	5.51	5.72	5.93
35	4.53	4.66	4.80	4.94	5.14	5.35	5.55	5.75



INIMATOR G6

DRIVER: _____
 EVENT: _____
 CLASS: _____
 TRACK: _____

- Clay Hard Packed Loose Dirt
 Carpet Asphalt Concrete
 Flat Banked True Oval Tri-Oval
 Traction: High Medium Low

LEFT	FRONT SUSPENSION	RIGHT
CAMBER		
CASTOR		
<input type="checkbox"/> +10° <input type="checkbox"/> +5° <input type="checkbox"/> 0° <input type="checkbox"/> -5° <input type="checkbox"/> -10° <input type="checkbox"/> +10° <input type="checkbox"/> +5° <input type="checkbox"/> 0° <input type="checkbox"/> -5° <input type="checkbox"/> -10°		
ACKERMANN		
<input type="checkbox"/> OUTER <input type="checkbox"/> MIDDLE <input type="checkbox"/> INNER <input type="checkbox"/> INNER <input type="checkbox"/> MIDDLE <input type="checkbox"/> OUTER		
AXLE SHIMS		
OUTER CAMBER LINK LOCATION		
<input type="checkbox"/> OUTER <input type="checkbox"/> INNER <input type="checkbox"/> INNER <input type="checkbox"/> OUTER		
<input type="checkbox"/> 0° <input type="checkbox"/> ANGLED KINGPIN INCLINE <input type="checkbox"/> ANGLED <input type="checkbox"/> 0°		
CAMBER RATE SHIMS		
SUSPENSION LOCATION		
<input type="checkbox"/> OUTER <input type="checkbox"/> MIDDLE <input type="checkbox"/> INNER <input type="checkbox"/> INNER <input type="checkbox"/> MIDDLE <input type="checkbox"/> OUTER		
KICK-UP: <input type="checkbox"/> 15° LO <input type="checkbox"/> 15° HIGH <input type="checkbox"/> 20° LO <input type="checkbox"/> 20° HIGH <input type="checkbox"/> 25° <input type="checkbox"/> 35°		
TOE: _____		
SWAY BAR: <input type="checkbox"/> NONE <input type="checkbox"/>		

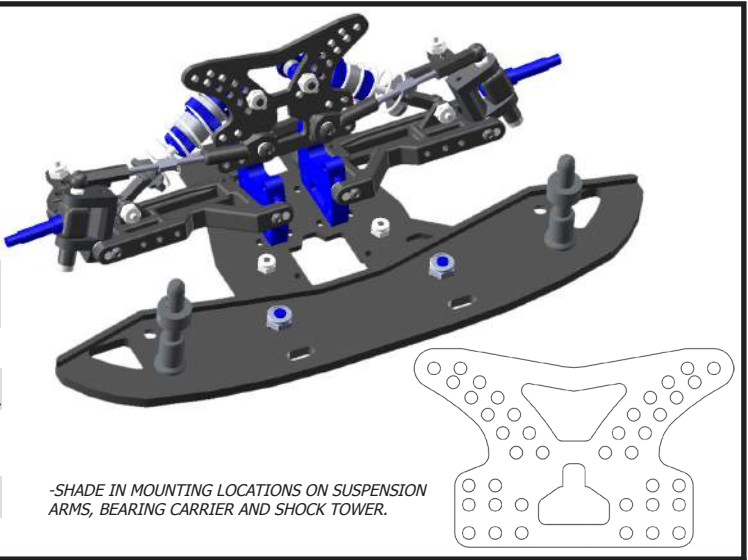

TIRES & TRACTION	
TIRE TYPE:	<input type="checkbox"/> FOAM <input type="checkbox"/> STREET RUBBER <input type="checkbox"/> LOOSE COMPOUND DIAMETER INSERT
RF:	_____
LF:	_____
RR:	_____
LR:	_____
CLEANED WITH:	_____
TRACTION ADDITIVE:	_____
NOTES:	_____

SHOCKS			
COLLAR LENGTH		SHOCK LENGTH	
LEFT FRONT		RIGHT FRONT	
BODY LENGTH		BODY LENGTH	
<input type="checkbox"/> SHORT <input type="checkbox"/> MED <input type="checkbox"/> LONG		<input type="checkbox"/> SHORT <input type="checkbox"/> MED <input type="checkbox"/> LONG	
SHAFT LENGTH		SHAFT LENGTH	
<input type="checkbox"/> SHORT <input type="checkbox"/> MED <input type="checkbox"/> LONG		<input type="checkbox"/> SHORT <input type="checkbox"/> MED <input type="checkbox"/> LONG	
SPRING: _____		SPRING: _____	
OIL: _____		OIL: _____	
PISTON: _____		PISTON: _____	
LENGTH: _____		LENGTH: _____	
COLLAR: _____		COLLAR: _____	
LEFT REAR		RIGHT REAR	
BODY LENGTH		BODY LENGTH	
<input type="checkbox"/> SHORT <input type="checkbox"/> MED <input type="checkbox"/> LONG		<input type="checkbox"/> SHORT <input type="checkbox"/> MED <input type="checkbox"/> LONG	
SHAFT LENGTH		SHAFT LENGTH	
<input type="checkbox"/> SHORT <input type="checkbox"/> MED <input type="checkbox"/> LONG		<input type="checkbox"/> SHORT <input type="checkbox"/> MED <input type="checkbox"/> LONG	
SPRING: _____		SPRING: _____	
OIL: _____		OIL: _____	
PISTON: _____		PISTON: _____	
LENGTH: _____		LENGTH: _____	
COLLAR: _____		COLLAR: _____	

LEFT	REAR SUSPENSION	RIGHT
CAMBER		
TOE		
WHEEL SPACERS		
<input type="checkbox"/> .250" <input type="checkbox"/> .125" <input type="checkbox"/> NONE <input type="checkbox"/> NONE <input type="checkbox"/> .125" <input type="checkbox"/> .250"		
BEARING CARRIER SPACING		
RIGHT: <input type="checkbox"/> FWD <input type="checkbox"/> 1-OFF FWD <input type="checkbox"/> MIDDLE <input type="checkbox"/> 1-OFF REAR <input type="checkbox"/> REAR LEFT: <input type="checkbox"/> FWD <input type="checkbox"/> 1-OFF FWD <input type="checkbox"/> MIDDLE <input type="checkbox"/> 1-OFF REAR <input type="checkbox"/> REAR		
<input type="checkbox"/> LONG <input type="checkbox"/> SHORT INNER SUSP MOUNT <input type="checkbox"/> SHORT <input type="checkbox"/> LONG		
ANTI-SQUAT SHIMS		
<input type="checkbox"/> 3° <input type="checkbox"/> 1.5° <input type="checkbox"/> NONE <input type="checkbox"/> NONE <input type="checkbox"/> 1.5° <input type="checkbox"/> 3°		
ROLL CENTER SHIMS		
<input type="checkbox"/> .125" <input type="checkbox"/> .060" <input type="checkbox"/> NONE <input type="checkbox"/> NONE <input type="checkbox"/> .060" <input type="checkbox"/> .125"		
OUTER CAMBER LINK LOCATION		
<input type="checkbox"/> OUTER <input type="checkbox"/> INNER <input type="checkbox"/> INNER <input type="checkbox"/> OUTER		
BEARING CARRIER PIN HEIGHT		
<input type="checkbox"/> HIGH R.C. <input type="checkbox"/> LOW R.C. (NEAR AXLE) <input type="checkbox"/> LOW R.C. <input type="checkbox"/> HIGH R.C.		

