

THE OUTLAW

1/10 Scale Sprint Car by
CUSTOMWORKS



#0720 ELECTRIC OUTLAW KIT

Manufactured by:
Custom Works RC Products llc
760-B Crosspoint Drive
Denver, NC 28037
www.customworksrc.com



REQUIRED READING...UNDERSTAND THIS MANUAL!

Thank You and Congratulations on purchasing the **OUTLAW!** Within this kit you will find a race winning car with over 21 years worth of **CUSTOM WORKS** design and quality. In order for you to realize this race car's winning potential it is important to follow the written text along with the pictures included. The steps required to build this car are very easy, as long as you read before you build.

The instructional format for building this car is to open each bag in alphabetical order. Each bag of parts will be broken down into "Steps" thru the manual. All parts and hardware needed to complete all steps for each separate bag, will be found in each individual bag. There is no need to steal screws from other bags. In the rare event you need to look in a different bag for a certain part, it will be noted clearly in the instructions.

Considering the various dirt or clay surfaces that Dirt Oval cars are raced on today, the Outlaw has been designed to be competitive on either loose packed dirt with buggy tires or high bite clay with rubber or foam racing tires. The instructions will build the kit using the most verastale set-up Custom Works has found in testing on different types of tracks, however there are various other suspension configurations available to you that you may find more suitable for your local track. For updates and more proven set-ups login to CustomWorksRC.com.

All hardware (screws, washers, nuts, etc...) are referred to by size and type in the instructions. To help clarify which screw or nut the instruction is calling for refer to the **HARDWARE REFERENCE** supplement. The size of the screw or nut should match the "shadow" of the same piece very closely.

Screw ID's are: **FH**=Flat Head **BH**=Button Head **SH**=Socket Head **SS**=Set Screw

BUILDING TIPS:

-Using some type of thread locking fluid is suggested for all parts where metal screws thread into other metal parts. We suggest using a lite setting strength thread lock for the reason you may want to take the screw out one day. Remember it only takes a very small amount to secure the screw.

-Do **NOT** use power screwdrivers to drive screws into parts. The fast rotation speed can easily melt and strip plastic parts or cross-thread into the aluminum parts.

-Lightly sand the edges of graphite pieces using a medium grade sandpaper to avoid splinters. Run a thin bead of Super Glue around the edges to give pieces greater durability.

SUGGESTED TOOLS

400 Grit Sandpaper

Hobby Scissors

Small Needle Nose Pliers

Wire Cutters

X-Acto Knife

Phillips Head Screw Driver

Blue Loctite

3/16" Wrench

Bag A Front Suspension



-Parts for Step#1						1:1		
	3332 Qty 1 1.4\" Front Susp Brace	3253 Qty 2 Front Susp Arms L&R	3258 Qty 2 Front Susp Mount	4240 Qty 2 Front Inner Susp Pin	5230 Qty 24 E-Clip	1:1		
-Parts for Step#2								
	1222 Qty 1 Outlaw Chassis	1272 Qty 1 Front Shock Tower	3228 Qty 1 Long Body Post	3228 Qty 1 Post Collar	3228 Qty 1 Set Screw	5253 Qty 4 4-40 x 3/8 BH Screw	5263 Qty 4 4-40 x 3/8 FH Screw	3229 Qty 1 8-32 x 1/2 FH Screw

STEP #1



- Insert 4240 Inner Pin thru 3332 Susp Brace, then thru first leg of 3253 Susp Arm and into 3258 Front Susp Mount.
- Snap 5230 E-Clips to 4240 Susp Pin.
- Arms should pivot freely on the mounts.

STEP #2

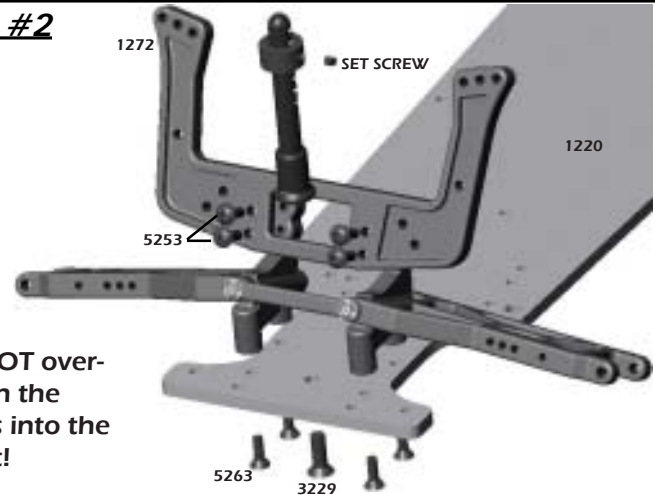

- Do NOT over-tighten the screws into the mount!
- Fasten the 1272 tower to the suspension assembly.
- Fasten the suspension assembly and the 3228 Body Post to the 1222 Chassis.

Bag B Steering Components



-Parts for Step#1					
	5249 Qty 4 Steel Turnbuckle	5235 Qty 8 Ball Cup			
-Parts for Step#2					
	3202 Qty 2 Steering Block L&R	7209 Qty 2 Ball Stud King Pin	7209 Qty 2 Spacer	7200 Qty 2 Front Axle	5004 Qty 2 6-20 Set Screw
-Parts for Step#3					
	3304 Qty 1 Steering Slide	3304 Qty 1 Steering Rack	8122 Qty 6 Ball Stud	5262 Qty 2 4-40 x 1/4 FH Screw	5217 Qty 2 4-40 Lock Nut

STEP #1



- Make 4 Linkages.



- Thread the 5235 Ball Cups onto the ends of the 5249 Turnbuckle.
- NOTE: Turnbuckle has RIGHT and LEFT threads!

1:1 Assembled Camber Link and Steering Linkage.

STEP #2

- Insert the 7200 Axle into the 3202 Steering Arm so the holes are in-line.

-Align the Steering Arm into the 3205 Castor Block and press the 7209 Ball Stud Kingpin thru the assembly as shown.

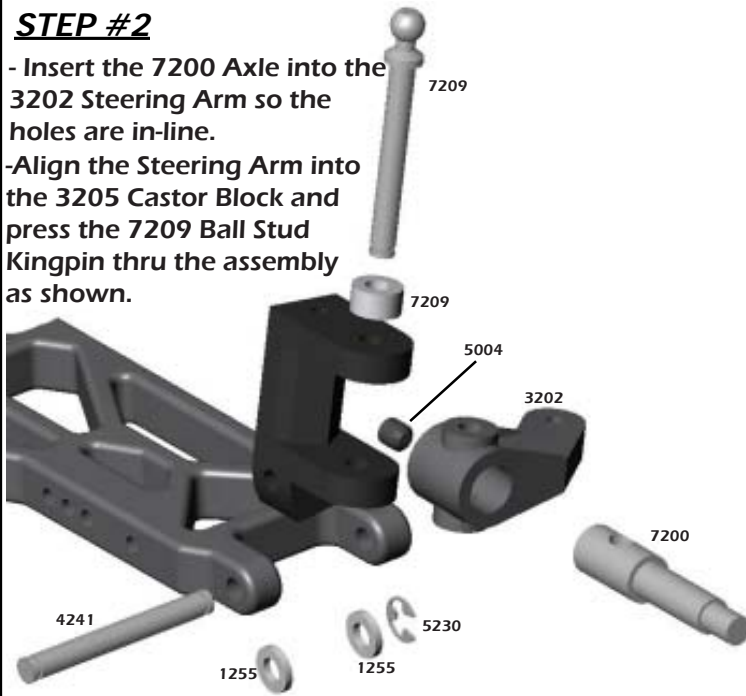

-Mount the Castor Block to the Susp Arm with a 1255 Spacer on each side of the Castor Block as it is fitted between the ears of the Susp Arm.

-Insert the 4241 Susp Pin thru the Susp Arm, Spacer, and Castor Block

-Retain the Susp Pin by attaching 5230 E-Clips to each end.

STEP #3

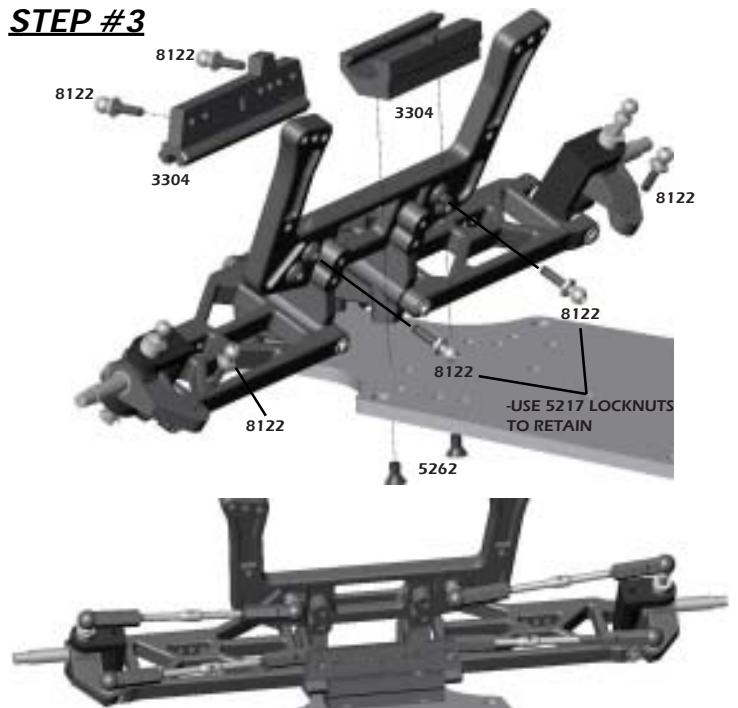

- Thread the 8122 Ball Stud into the front face of 3304 Steering Slide, back face of the shock tower, and top face of the Steering Arm as shown.

-Insert the Steering Slide into the 3304 Steering Rack, mount the rack to the chassis.

-Mount the linkages from Step #1 by snapping the Ball Cups onto the Ball Studs.

Bag C Rear Suspension



-Parts for Step#1	 1273 Qty 1 Rear Bulkhead	 3257 Qty 2 Tall Shock Ear	 3305 Qty 1 Tail Tank Tray	 5254 Qty 4 4-40 x 1/2 BH Screw	 5263 Qty 4 4-40 x 3/8 FH Screw	 5253 Qty 2 4-40 x 3/8 BH Screw
-Parts for Step#2	 3254 Qty 2 Long Rear Susp Arm	 2230 Qty 2 3 Deg Toe Block	 4234 Qty 2 Rear Inner Susp Pin	1:1	 5264 Qty 6 4-40 x 1/2 FH Screw	 5230 Qty 24 E-Clip

STEP #1

-Attach the 3257 Long Shock Ears to the 1273 Bulk to the side facing away in the diagram.

-Attach the 3305 Tail Tank Tray as shown in the diagram.



STEP #2

-Attach the 3254 Susp Arm to the 2230 Toe Block using the 4234 Susp Pin.
-Retain the pin with 5230 E-Clips.
-Make a RIGHT and LEFT assembly!

-NOTE: Back side of Toe Block for proper direction!

-LEFT Side Assembly Shown.

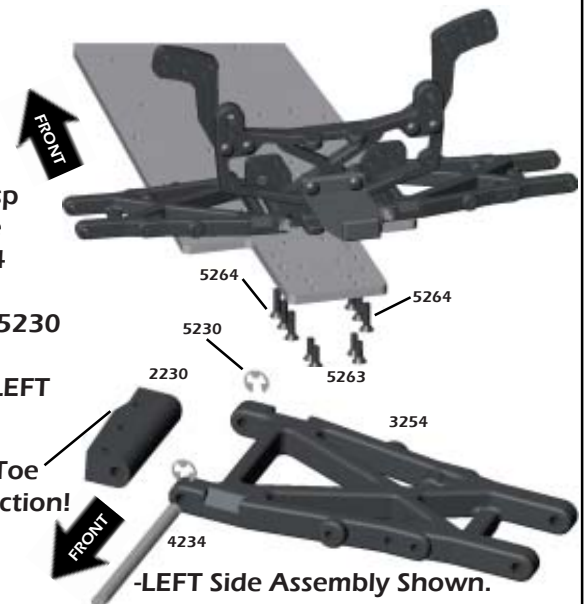

Bag D

Rear Suspension



-Parts for Step#1	3241 Qty 2 Bearing Carrier	1226 Qty 4 Ball Bearing	4235 Qty 2 Rear Outer Susp Pin	1255 Qty 10 Spacer	5230 Qty 24 E-Clip	
-Parts for Step#2	7211 Qty 2 CVD Coupling	7214 Qty 2 Medium Dogbone	7216 Qty 2 Rear CVD Axle	7211 Qty 2 Rear CVD Pin	7211 Qty 2 CVD Set Screw	
-Parts for Step#3	5249 Qty 2 Steel Turnbuckle	5235 Qty 4 Ball Cup	7047 Qty 6 Spacer	8122 Qty 4 Ball Stud	7203 Qty 2 Roll Pin	5217 Qty 2 4-40 Lock Nut

STEP #1

- Press 1226 Ball Bearings into the 3241 Bearing Carrier.
- Attach the Bearing Carrier to the Susp Arm using 4235 Susp Pin with (2) 1255 Spacers on each side of the Bearing Carrier.
- **NOTE: The Suspension Pin will pass thru the UPPER hole in the Bearing Carrier.**
- Retain the Susp Pin using 5230 E-Clips.

STEP #2

- Apply grease to the areas shown.
- Apply thread-lock (Loctite) to the set screw.
- Align the holes as shown so that the 7211 CVD Pin can pass thru the Bone, Axle, and Coupling. Pin should be evenly spaced in the DogBone.
- Tighten the Set Screw by angling the Bone and Axle so the set-screw is able to be tightened.

STEP #3

- Attach the 8122 Ball Stud to the Rear Bulkhead as shown using a 5217 Lock Nut.
- Slide a 1255 Spcaer onto the Ball Stud and thread into the Bearing Carrier in the outer most hole.
- Insert the CVD assembly by sliding the axle thru the bearings.
- Slide (4) 7047 Shims onto the axle and retain using the 7203 Roll Pin. Pin should be evenly spaced in Axle.
- Attach the Camber Link by snapping the Ball Cups onto the Ball Studs.

Bag E Diff Assembly



-Parts for Step#1	4365 Qty 1 Right Outdrive	4358 Qty 2 Diff Ring	4205 Qty 2 Thrust Washer	4361 Qty 1 Diff Bolt Cover	4204 Qty 6 Thrust Balls	4361 Qty 1 Diff Bolt	1:1	1229 Qty 2 5/32 x 5/16 Bearing
-Parts for Step#2	4364 Qty 1 Left Outdrive	4362 Qty 1 Diff Spring	4356 Qty 1 Diff Gear	4357 Qty 12 Diff Balls	4361 Qty 1 Diff T-Nut			

STEP #1

CUSTOM-TIP!!!
 -Using 400 Grit Sandpaper in a "Figure 8" pattern, it is best to sand the surfaces of both the 4404 Diff Ring and 4205 Thrust Washers. The textured surface results in a smoother and longer lasting diff.

- Slide a 4205 Thrust Washer onto the Diff Bolt.
- Apply a thick layer of Black Grease to the Thrust Washer, press (6) 4204 Thrust Balls into the Black Grease.
- Slide the other Thrust Washer on the Diff Bolt and insert it into the 4402 Left Outdrive.
- Press (1) 1229 Bearing into the Outdrive.
- Put (1) 4404 Diff Ring on the Outdrive, apply Diff Lube as shown.

STEP #2

- Press a small amount of Diff Grease into each of the small holes in the 4356 Diff Gear.
- Press (1) 1229 Bearing and the (12) 4357 Diff Balls into the Diff Gear.
- Put (1) 4358 Diff Ring onto the 4364 Right Outdrive, apply Diff Grease as shown.
- Install the 4362 Diff Spring and 4361 T-nut into the Outdrive.
- Carefully slide the diff assembly together so the Diff Bolt passes thru the entire assembly and threads into the T-nut.
- Screw the Diff Bolt into the T-nut until you feel the Diff Spring fully compress. **DO NOT OVERTIGHTEN!!!**
- Back the Diff Bolt off EXACTLY 1/8 of a turn. Diff motion should be smooth and the Outdrives will turn in opposite directions.

Bag F Transmission Casing



-Parts for Step#1 & Step#2	4352 Qty 1 Transmission Halves	4354 Qty 1 Idler Gear	4355 Qty 1 Idler Pin	4370 Qty 6 Thin Spacer	7047 Qty 8 Thin Shim	1230 Qty 2 3/8 x 5/8 Bearing	1226 Qty 4 3/16 x 3/8 Bearing
	4368 Qty 1 Top Drive Shaft	5291 Qty 3 4-40 x 1 1/8 BH Screw	1:1	5263 Qty 4 4-40 x 3/8 FH Screw	4406 Qty 1 Top Shaft Roll Pin	4352 Qty 3 Motor Plate Spacer	2225 Qty 1 Motor Plate

STEP #1





- Press the (2) 1230 Bearings and (4) 1226 Bearings into each 4352 Transmission Half.
- Slide 4370 Thin Washers on each side of the 4368 Top Drive Shaft as shown.
- Insert the Diff Assembly, Top Drive Shaft, 4352 Pin, and Idler Gear into the RIGHT Trans Half. Diff Screw should be on the RIGHT side!
- Align the LEFT Trans Half over the gears. Space the Trans Halves apart using (2) 1226 Shims per screw location.
- Diff Screw should be on the RIGHT side of the Trans!

STEP #2

- Press the 4406 Pin into the Drive Shaft.
- Fasten 2225 Motor Plate by tightening the XXXX Screws with 4352 Spacers.

Bag G Spur Gear Assembly











-Parts for Bag G					
	2228 Qty 1 Slipper Eliminator	4881 Qty 1 81T 48P Spur Gear	5252 Qty 2 4-40 x 1/4 BH Screw	2228 Qty 1 Spacer	5245 Qty 1 5-40 Locknut



- Press the 2228 Slipper Eliminator onto the Top Drive Shaft so that the Roll Pin keys into the grooves.
- Secure the assembly to the Top Shaft with the 2228 Spacer and the 5245 Locknut. Do NOT overtighten the nut on the Top Shaft!
- Mount the 4881 Spur Gear so the flat side faces AWAY from the transmission. Secure using (2) 5252 Screws.

Bag H Transmission Mount



-Parts for Bag I					
	3308 Qty 1 Transmission Brace	3229 Qty 1 Post Collar	1202 Qty 1 Trans Spacer	3229 Qty 1 8-32 x 1/2 FH Screw	5262 Qty 1 4-40 x 1/4 FH Screw
					
	3229 Qty 1 Short Body Post	3229 Qty 1 Set Screw	5264 Qty 2 4-40 x 1/2 FH Screw	5253 Qty 4 4-40 x 3/8 FH Screw	

- Attach 3229 Body Post to 3308 Trans Brace using 3229 Screw.
- Slide 3201 Post Collar onto the Body Post and secure using 3229 Set Screw.
- Mount the 1202 Trans Spacer to the Chassis using the 5262 Screw where shown.
- Secure the Trans to the Chassis using (2) 5264 Screws thru the 1202 Trans Spacer as shown.
- Attach the 3308 Trans Brace to the Trans and Rear Bulkhead using 5253 Screws.
- Mount the Trans Brace to the Trans and Rear Bulkhead using 5253 Screws.
- NOTE: Align the dogbone shafts into the outdrives of Trans as you mount the trans!



- NOTE: Align the dogbone shafts into the outdrives of Trans as you mount the trans!

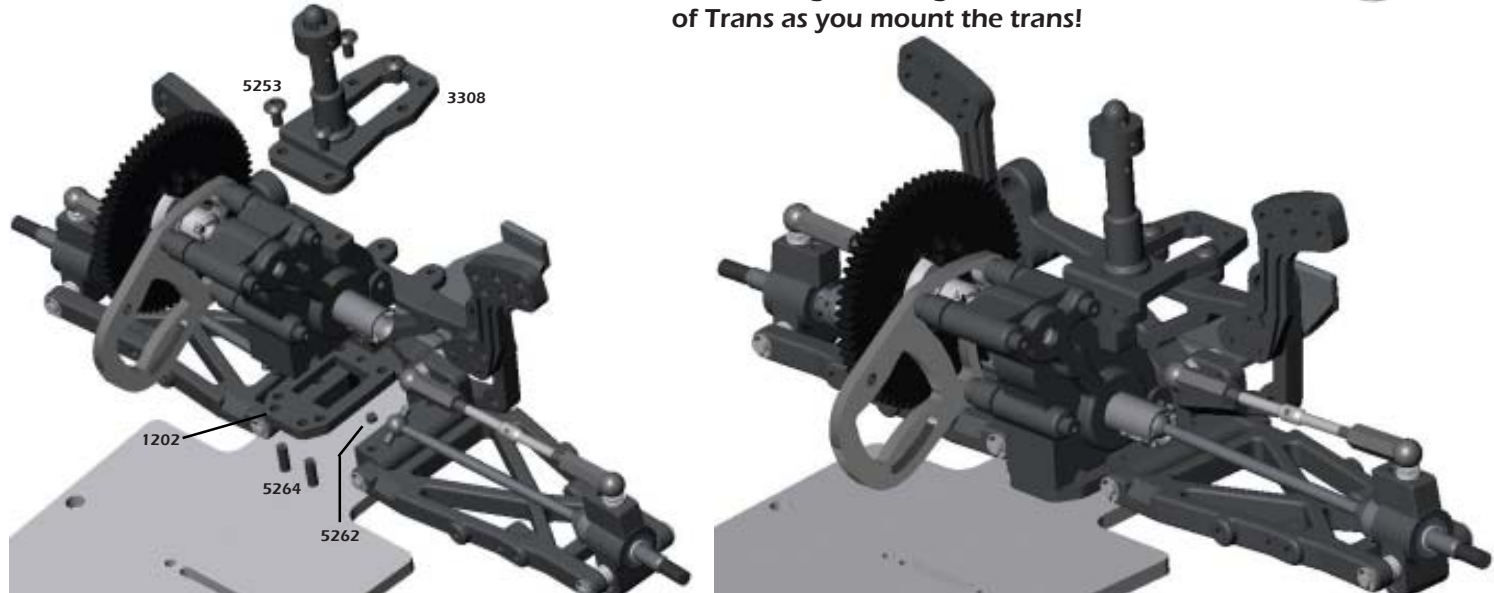

Shock Bag

Shock Assembly



-Parts for Step#1	1424 Qty 4 Long Shock Body	1428 Qty4 Long Shock Shaft	1434 Qty4 Shaft Guide	1250 Qty 8 O- Ring	1435 Qty 8 Retaining Clip	1436 Qty4 Piston	5230 Qty 10 E-Clip
-Parts for Step#2	1432 Qty4 Eyelet Cap	1431 Qty4 Threaded Cap	1437 Qty 4 Soft Bladder (BLUE)	5228 Qty4 Short Ball End	5228 Qty4 Pivot Ball		
-Parts for Step#3	1433 Qty4 Spring Collar	1477 Qty4 Spring	1407 Qty4 Spring Bucket	1408 Qty4 Mount Ball	5277 Qty 4 4-40 x 7/8 SH Screw	5274 Qty 4 4-40 x 1/2 SH Screw	5217 Qty 8 4-40 Lock Nut

STEP #1

NOTE: Put a few drops of oil on the O-Rings!

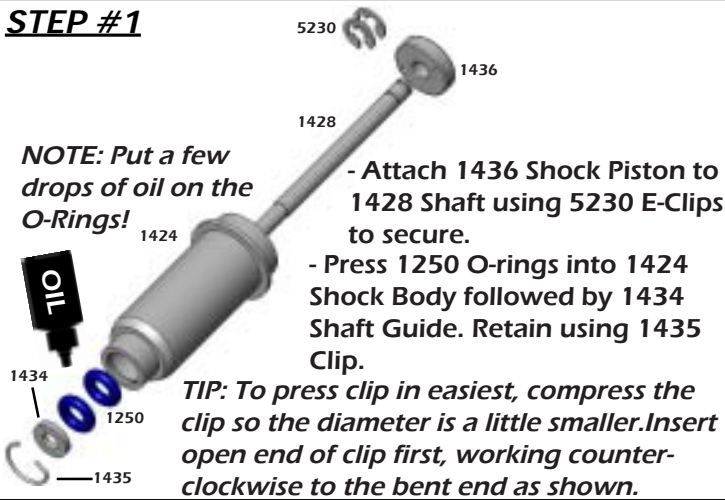

- Attach 1436 Shock Piston to 1428 Shaft using 5230 E-Clips to secure.
- Press 1250 O-rings into 1424 Shock Body followed by 1434 Shaft Guide. Retain using 1435 Clip.

TIP: To press clip in easiest, compress the clip so the diameter is a little smaller. Insert open end of clip first, working counter-clockwise to the bent end as shown.

STEP #2

- Snap Pivot Ball into the 5228 Ball End. Thread the Ball End onto the Shock Shaft until the Ball End is flush with the end of threads on the shaft.
- Press 1432 Eyelet Cap into 1431 Threaded Shock Cap so that guide in the Eyelet Cap lines up in the recess in the Threaded Shock Cap.
- Press the 1437 Firm Bladder (BLACK) into the Threaded Shock Cap so the dome of the bladder points away from the Eyelet Cap.
- Fill the Shock Body with oil to the top then thread the Eyelet Cap assembly onto the Shock Body until tight.
- NOTE: See shock filling tips for more instructions.

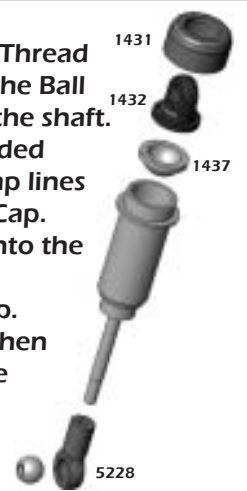

SHOCK FILLING INSTRUCTIONS: Filling Shocks: Steps 1-4 Setting Shock Rebound: Steps 5-8

1) Holding the shock upright, fill with oil until the top of the body.



2) Slowly move the shaft up and down several times to allow air bubbles to escape to the top.

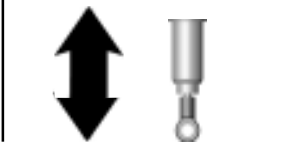

3) Refill with oil to the top of the shock body.



4) Thread the Eyelet Cap assembly onto the Shock Body until it is hand tight. Oil should seep out of the bleed hole in the Threaded Cap.

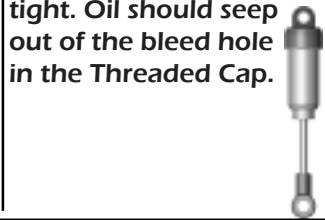

5) Move the shock shaft in and out a few times and then push it all the way in. It should be easy to push the shaft in until the eyelet hits the body.

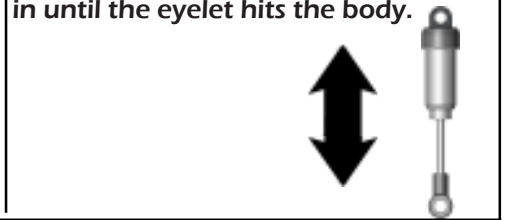

6) Then the shaft should push itself out to its full length slowly.

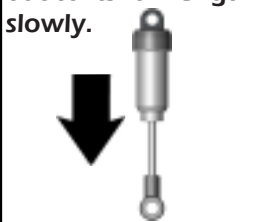

7) If the shock does not push out this far there is not enough oil in it. Add just a little oil and try steps 5-6 again.



8) If the shockrebounds too fast , or you cannot push the shaft in until the eyelet hits the body, there is too much oil. Loosen the cap and pump out a small amount of oil by pushing the shaft in. Re-tighten the cap and try steps 5-6 again.

STEP #3

- Thread 1433 Spring Collar onto the shock. Slide 1477 Spring onto the shock and secure using the 1407 spring bucket as shown.
- Press 5277 Screws thru the inner most holes on the front tower and thru the upper/middle set of holes on the rear tower. Secure using 5205 Nut.
- Install the shocks onto the screws with the shoulder of the 1408 Mount Ball facing the tower, secure with 5217 Nut.
- Attach the shock to the susp arms in the outer most holes on both front and rear arms as shown.

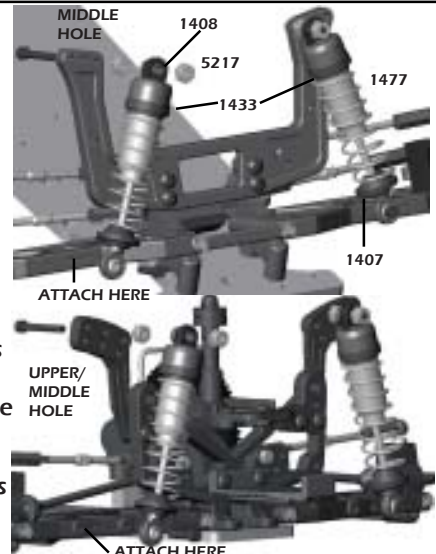

Bag I

Battery Mount



-Parts for Bag J



3224 Qty 1
Battery Tray



2004 Qty 2
Strap Mount



3009 Qty 1
Strap Buckle



3009 Qty 2
Battery Strap



5263 Qty 4
4-40 x 3/8 FH Screw

1:1

STEP #1

- Slide the 2004 Strap Mount thru the small loop on the 3009 Battery Strap.
 - On the marked spots, drill the (4) holes in the 3224 Battery Tray so they align with the holes in the chassis.
 - Mount the Tray to the Chassis using 5263 Screws thru the Chassis and into the 2004 Strap Mount.
 - Peel apart both 3009 Battery Straps. Insert one Strap end thru the Buckle and re-attach to itself. Then slide the end of the other Strap thru the Buckle, pull tight to the Battery and attach to the velcro.
- NOTE: Battery packs come in a variety of widths, it may be necessary to alter the Tray by cutting away the left side of the tray and/or re-aligning the holes it mounts in.

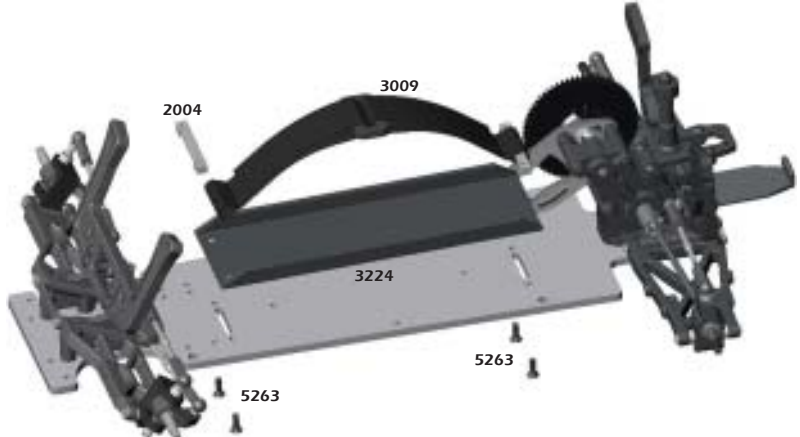

Bag J

Servo and Linkage Installation



-Parts for Steps #1



5242 Qty 1
Large Servo Saver



8130 Qty2
Small Ball Cup



8122 Qty 2
Ball Stud



3234 Qty2
Spacer



5263 Qty 5
4-40 x 3/8 FH Screw

1:1



5240 Qty2
Servo Mount



5281 Qty1
4-40 Stud



3209 Qty1
Antenna Mount



5253 Qty 4
4-40 x 3/8 BH Screw

1:1

STEP #1

- Attach 5240 Servo Mounts to your steering servo in the position shown using 5253 Screws.
- Thread 8120 Ball Stud into the upper-most center hole in the 5242 Servo Saver.
- Attach both 8130 Ball Cups to one another using the 5281 Stud until the Ball Cups bottom out on one another. Snap a Ball Cup onto the Ball Stud on the Servo Saver.
- Determine which of the Spline Inserts are correct for your servo by pressing it over the drive on the servo. Align the servo so it has equal throw in both directions.
- Press the Servo Saver onto the Spline Insert so that the Servo Saver is perpendicular to the servo, attach using the screw that came with your servo.

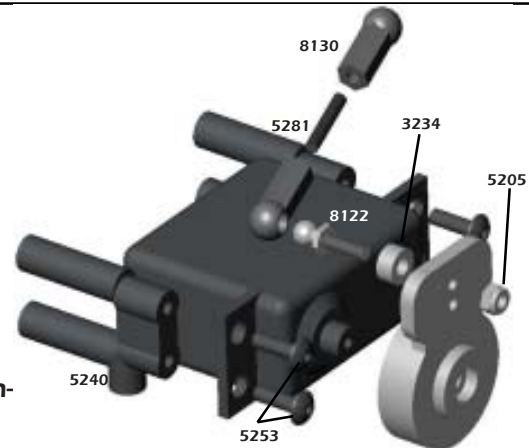

STEP #2

- Mount the servos to the chassis using 5263 Screws as shown.
 - Thread 8122 Ball Stud with the 3234 Spacer into the top of the Steering Slide.
 - Snap the Ball Cup onto the Ball Stud threaded into the Steering Slide.
 - Attach 3209 Antenna Mount in either of the two holes shown below.
- NOTE: Steering movement should be bind free except for the restriction of the servo transmission.

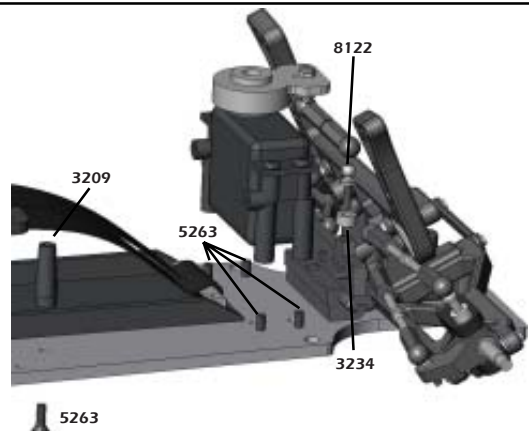

Cage Bag Cage Assembly



-Parts for Step #1 & Step #2							
	3233 Qty 2 Rear Bumper	3233 Qty 1 Bumper Connector	3239 Qty 1 Front Cage Mount	5255 Qty 4 4-40 x 5/8 BH Screw	5254 Qty 6 4-40 x 1/2 BH Screw	5253 Qty 2 4-40 x 3/8 BH Screw	5262 Qty 2 4-40 x 1/4 FH Screw
-Parts for Step #3 & Step #4							
	3235 Qty 2 Main Cage Half	3233 Qty 1 Front Bumper	3232 Qty 1 Nerf Bar L & R	3232 Qty 1 Nerf Support L & R	3235 Qty 2 Upper Cage Brace	3421 Qty 2 Wing Slide Bushing	
	5278 Qty 2 4-40 x 1" SH Screw	5279 Qty 2 Hole Head Screw LONG	5280 Qty 2 Hole Head Screw SHORT	5274 Qty 4 4-40 x 1/2 SH Screw	5264 Qty 3 4-40 x 1/2 FH Screw		

STEP #1

- Mount the (2) 3233 Rear Bumpers together using 5253 Screws and the 3233 Bumper Connector.

- Attach the Bumper Assembly to the Rear Bulkhead using 5255 Screw into the upper bumper and 5254 Screw into the lower bumper as shown.

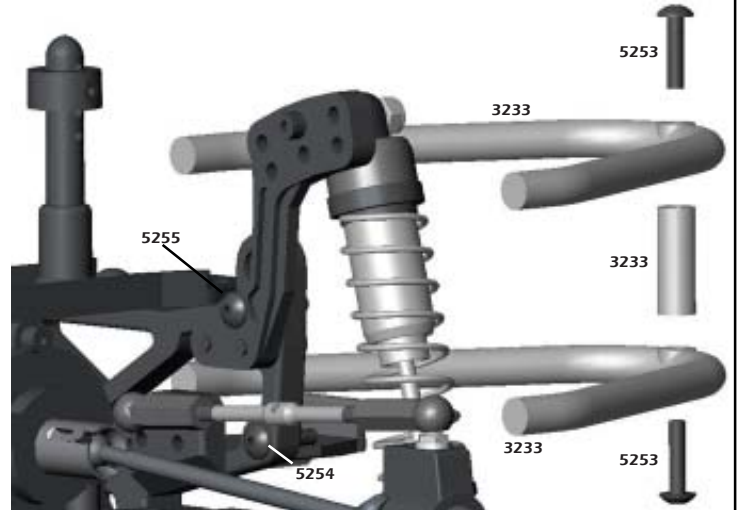

STEP #2

- Mount the 3239 Front Cage mount to the chassis using 5262 Screws.

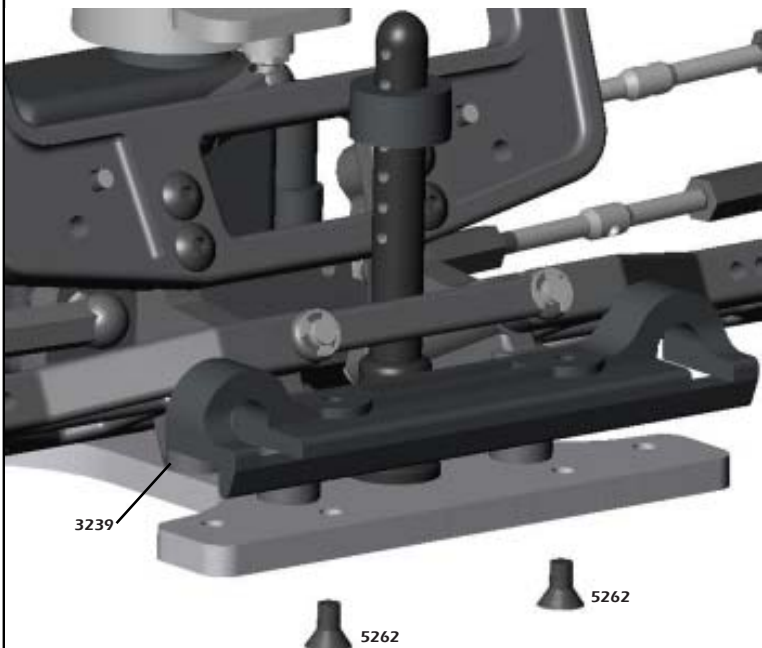

STEP #3

- Assemble the Nerf Bar and Nerf Bar Support using 5254 Screw.

NOTE: Right and Left Nerf Bars and Supports come in the cage kit. Shown is the RIGHT assembled part. When using the correct Support with the Nerf Bar, the bottom foot of the Support and the short leg of the Nerf Bar will be parallel.

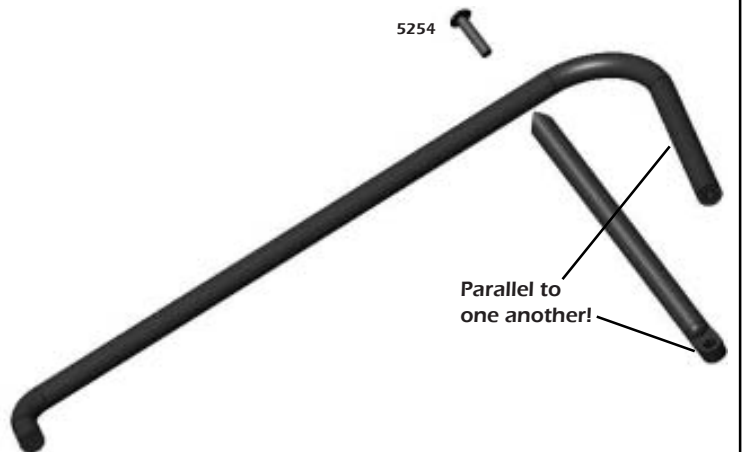

STEP #4



- Mount 3233 Front Bumper using 5278 Screws.
- Mount the 3421 Wing Slide Bushing to the Cage using 5254 Screws thru the Bushing and Cage and into the 3235 Upper Cage Brace.
- Use the (2) Long 5279 Hole Head Screws mount the 3235 Upper Cage Braces onto the top of the Main Cage Halfs.
- Use the remaining (2) Short 5280 Hole Head Screws in the back of the Main Cage Halfs.

NOTE: Do NOT tighten all the way down, leave a gap of .100" between the screw head and cage.

- After completing the Body Panel steps, Attach the rear of the Nerf Bar using the 5254 Screw thru the cage as shown. Attach the front of the Nerf Bar and the Nerf Bar Support to the bottom of the "legs" on the Main Cage Half using 5274 Screws.

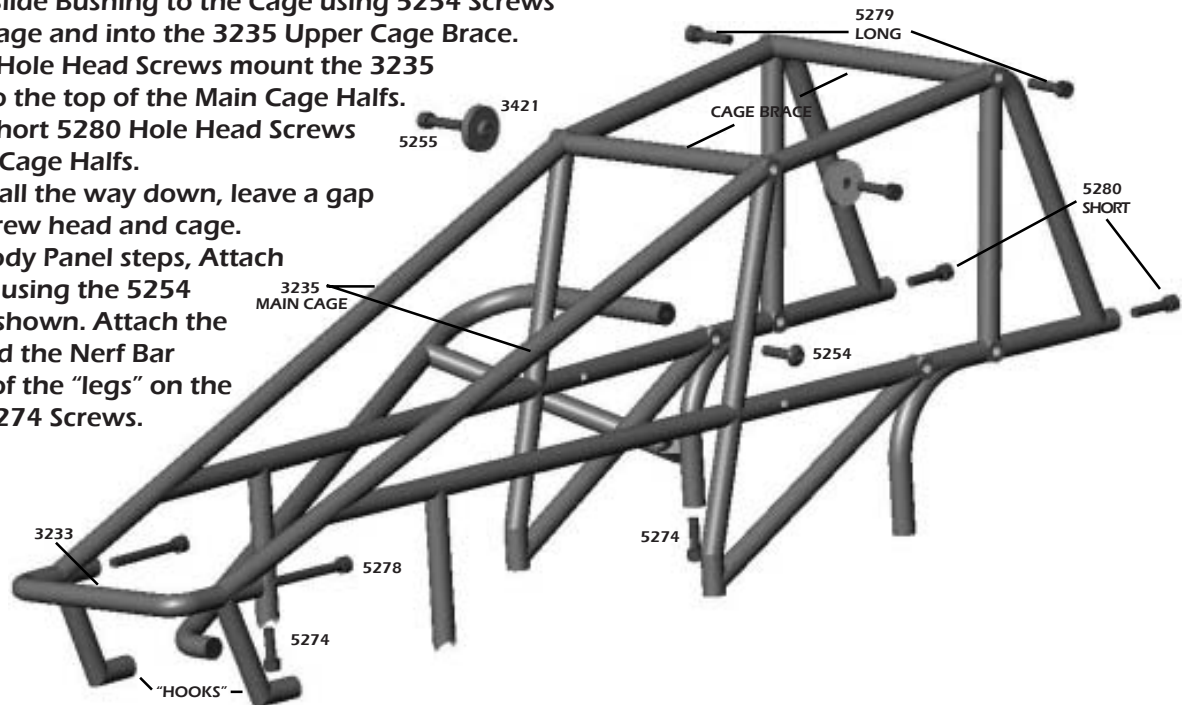

CAGE INSTALLATION AND REMOVAL:

- Place the cage between the front suspension tower with the "HOOKS" slightly further forward than the front edge of the chassis.
- Guide the "HOOKS" into the Front Cage Mount while guiding the Short 5280 Hole Head Screws into the Rear Bulkhead.
- Position the (2) 5274 Screws that mount the bottom portions of the nerf bars to the Cage Half into the holes in the Chassis.
- Lock the cage by placing 9936 Clip into the Hole in the Head of the 5280 Screw.

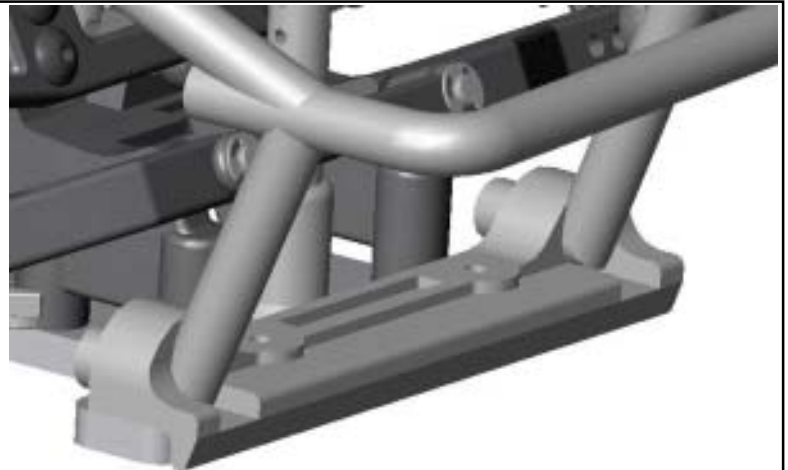

Body Panel Bag

Body Panel Prep & Mounting

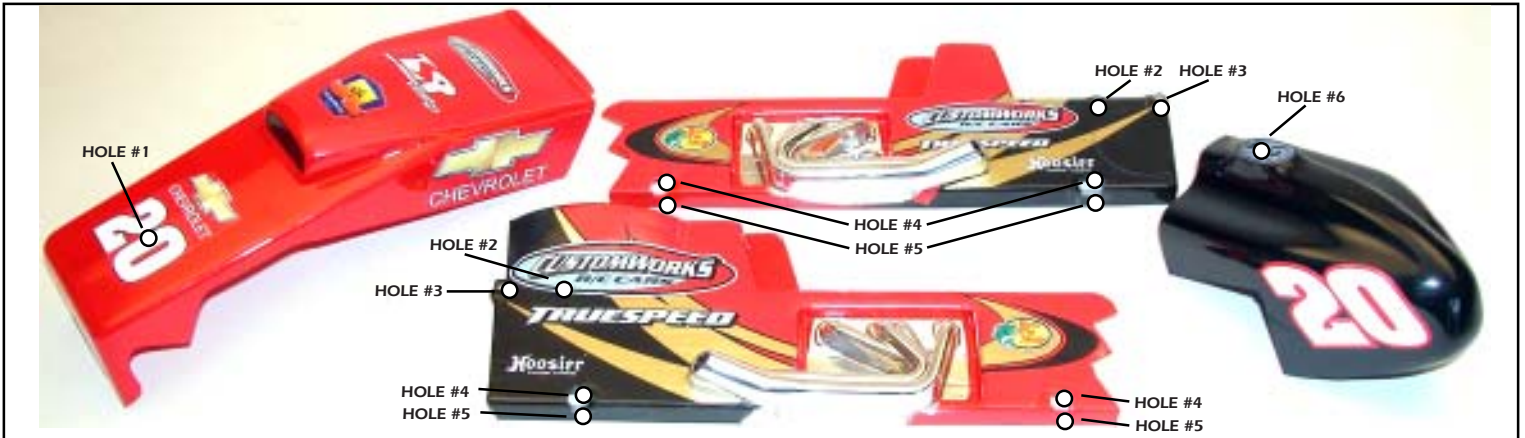

- **Do these steps BEFORE painting your body panels!!!**
- Cut the 9024 Left Body Panel to fit the Body Template provided.
- Use the Body Template ONLY to cut the front edge of the Right Body Panel.
- Follow the molded lines on the 9029 Eagle Hood and 9026 Tail Tank.
- Additional trimming may be required to clearance suspension movements.

BODY HOLE NOTES:

HOLE #1: Fit the Side Panels and Hood to the Cage, make a mark where the Body Post meets the Hood.

HOLE #2 & #3: Use the marks in the body panel, make a small hole only the screw can pass thru.

HOLE #4: Use the marks provided so the nerf bar can pass thru the body panel.

HOLE #5 & #6: Use the provided body line or mark molded into the Body Panel.



Tire Bag Tire & Wheel Installation



-Parts for Bag M									1:1		1:1
	6204 Qty 2 Street-Trac FRONT	6214 Qty 2 Street-Trac REAR	6220 Qty 2 Soft Insert FRONT	6221 Qty 2 Soft Insert REAR	6252 Qty 2 Front Wheel	6253 Qty 2 Rear Wheel	5207 Qty 4 8-32 Lock Nut	1226 Qty 4 Ball Bearing		7047 Qty 6 Spacer	

NOTE: In this step you will be using a fast drying super glue type adhesive to secure the tires and wheels to each other. Be very careful with this process as the glue can tend to run very easily through the tire and may glue your finger to the tire or wheel before you know it. You must follow the directions and precautions provided by the glue manufacturer to insure a secure bond.

STEP #1: Using a reamer or a small drill bit make a hole in the center of each of the 4 wheels as shown in **Figure 1**.

STEP #2: Place the foam inserts into the tires with the wider inserts going in the rear tires, the narrower in the fronts. Make sure the insert is laid into the tire evenly. As shown in **Figure 2** it should not be bunched up too much in any area.

STEP #3: Place the wheel inside of the tire and work both beads of the tire into the channels on the outside edge of the wheel. Peel back a portion of the tire from the wheel and apply an even bead of tire glue between the wheel and the tire as shown in **Figure 3**. Repeat this step several times working your way around the tire until it is secure. You may repeat this process now for the remaining 3 tires **BUT BE SURE TO PLACE THE FRESHLY GLUED SIDE UP** until it has dried completely. Once dry it is a good idea to go back and re-seal the edges by applying another small bead of glue and letting it run around the edge of the tire at the gap between tire and wheel.

STEP #4: Once the tires have completely dried you may now mount them to the car. Place one #1226 Bearing into each side of the front wheels as shown in **Figure 4**.

STEP #5: Refer to **Figure 5** and place one 3/16" shim over the front axle followed by the front wheel and then another 3/16" shim. Now secure with one 5207 Locknut, be very careful to not overtighten the nut. you want to tighten it just enough to eliminate any slop from side to side but no more. Repeat for other side of car.

STEP #6: Now slide one of the rear wheels onto the rear axle as shown in **Figure 6**. Be sure to index the roll pin in the axle so that it slides into the drive slot molded in the back of the wheel. Now secure with a 5207 locknut. Be sure not to over tighten as you can bend the roll pin.



Figure 1



Figure 2



Figure 3



Figure 4



Figure 5



Figure 6

Top Wing Tire & Wheel Installation



- Assemble the #9021 Wing Kit using the instructions provided inside the wing kit. Mount the wing to the car and it should now look just like the car shown below.



CONGRATULATIONS!!! You have now completed the assembly process of your new Custom Works Nitro Outlaw. In the next section of this manual you will find some basic setup hints and advice. It is important to remember that all tracks and racing surfaces are different. Therefore the suggestions we give you are general in nature and should by no means be treated as the only options.

MAINTENANCE:

Occasionally dirt will get into the moving and pivoting locations in your car. It is best to periodically clean your car to keep all the suspension components moving freely. Read the tips below to keep your car running at its best!

- Begin by removing the majority of the dirt using a small brush, toothbrush, or compressed air.
- Compressed air is ok to use, be mindful to not FORCE the dirt into the radio gear, transmission, bearings, or air filter. Typically these items only have dirt on them, hitting the dirt with the compressed air puts dirt **IN** these parts!
- Tires, either foam or rubber are best cleaned using water or cleaners like Simple Green (TM). Simple Green also does a great job cleaning car parts as well. Lightly spraying car parts (NOT radio components, transmission, air filter, or bearings) with Simple Green and blowing off with compressed air or wiping the parts using the paint brush is a great way to clean in a hurry.
- Another R/C friendly cleaner is WD-40 (TM). After the car is clean, very lightly spray the car components and bearings (NOT radio components, transmission, or air filter). Use your brush or compressed air to remove the extra WD-40. This will lube your bearings and leave a protective coating on the parts making it easier to remove dirt later.
- Differential Maintenance is needed when the action of the diff feels “notchy”. Usually cleaning the diff parts, re-sand the thrust and diff plates with 400 paper, and lube appropriately will be all that is needed to bring back to new. Ignoring your differential will lead to handling woes and increase transmission temps, which will cause part failure.

TUNING TIPS: These are some general guidelines for optimizing handling performance. None of these “tips” are EVER set in stone. On any given day this manual or any chassis engineering book or guru can be proved wrong by the stop watch. A good way to approach chassis set-up is to try one change, practice it, think how the car felt different from before, and compare lap times from the stop watch.....this will never fail.

<u>Car Pushes (understeers):</u>	<u>Car Is Loose (oversteers):</u>	<u>Car Is Erratic:</u>
<ul style="list-style-type: none"> - Decrease Wing Angle - Decrease Spoiler on Wing - Heavier Rear Spring - Softer Front Spring - Use Rear Sway Bar - Try Softer Front Compound Tire - Try Harder Rear Compound Tire - Lower Front Ride Height - Raise Rear Ride Height - Thread Shock Collar UP on Right Front - Thread Shock Collar DOWN on Right Rear - Decrease Rear Toe - Decrease Castor - Add Rear Toe Stagger or Increase the difference 	<ul style="list-style-type: none"> - Increase Wing Angle - Add Spoiler to Wing - Softer Rear Spring - Heavier Front Spring - Use Front Sway Bar - Try Harder Front Compound Tire - Try Softer Rear Compound Tire - Raise Front Ride Height - Lower Rear Ride Height - Thread Shock Collar DOWN on Right Front - Thread Shock Collar UP on Right Rear - Increase Rear Toe - Increase Castor - Decrease Rear Toe Stagger or Decrease the difference 	<ul style="list-style-type: none"> - Bent Suspension Pins: Remove shocks to check free movement. - Bound Ball Joint: Should spin free on balls while mounted to the car. - Bent or Loose Camber Links - Wore out Bearings or Completely Seized Bearings - Chunked Tire: Check to see if Foam or Rubber Tire is still glued to wheel. - Loose Screws: Especially Chassis Screws, add Blue Loctite to prevent. - Shocks: Either Bound-up or Out of Oil. Must swivel freely on mounts. - Foreign Objects: Unlucky Dirt/Stones preventing Suspension or Steering Movement. - Blown Differential - Radio Problem: Bad Servo, Weak Servo Saver Spring, Transmitter Pot blown.

SET-UP GUIDELINES:

When looking for the "perfect set-up" it is important to remember 2 things...

- 1) Keeping things simple is best.
- 2) As you are making your set-up change, the track is changing too! Ask a local racer what the track usually does from beginning to end, especially day to night.
 - Start your car's ride height with it equal at all four corners to start. Use the shock collars to adjust ride height by measuring the distance under the chassis when the car is sitting on a FLAT & LEVEL surface.
 - Shock collars can only jack weight and adjust the car's handling when the car makes ALL 4 shocks squat when the car is set down. Use the RF shock collar to adjust how the car ENTERS the corner. Use the RR shock collar to adjust how the car exits the corner ON-POWER. Use the LF shock collar to make the car turn in less, and off the corner more.
 - It is best to have a little bit of brake drag when you let off the gas, this will allow for a more controllable car in ALL conditions. Increasing how much the brake drags will make your car turn into the corner harder.

SET-UP GLOSSARY:

Caster: Angle of the kingpin in relation to a vertical plane as viewed from the side of the car. Increasing the angle will make the car more stable out of the turn and down the straights and increase steering entering a turn. Decreasing the angle will make the car feel more "touchy" at high speeds and help steering while exiting the turn.

Camber Gain: Angle of the Camber Link relative to the Suspension Arm. Lowering the camber link on the shock tower OR raising the camber link on the castor block will INCREASE the camber angle of the tire when the suspension is compressed. Raising the camber link on the shock tower OR lowering the camber link on the castor block will DECREASE the camber angle of the tire when the suspension is compressed. There is not a "correct" set-up and once again too much of anything is generally bad. This will help change the "feel" of the car thru the turns.

Camber Link Length: Comparing this to the length of the Suspension Arm from each pivot point and keeping the Camber the same, making the link *shorter* will decrease traction for that corner of the car while making it *longer* will increase traction for that corner of the car. Once the camber link is equal to or greater than the Suspension Arm pivots, the gain of traction ends. Also a shorter camber link will increase camber gain and a longer decrease camber gain.

Shock Angle: Leaning the shock toward the car is effectively like changing to a *softer* spring. Standing the shock closer to vertical is effectively like changing to a *stiffer* spring. Try when the car is working well and when one spring change is TOO much for your set-up.

Ride Height: Check by pushing the chassis down once or twice to simulate bumps on the track. Having the front end *higher* than the rear will make the car increase rear traction especially out of the turn. Having the front end *lower* than the front will make the car increase front traction especially entering the turn. Generally its safe to start the car with the ride heights even.

Rear Toe-In: Front edge of car tires point *toward* the chassis as viewed from above the car. Increasing the angle toward the car will increase rear traction while decreasing front traction. Decreasing the angle will do the opposite.

Rear Toe Stagger: Difference in the amount of Rear Toe-In among the rear tires. Typically used only on high bite tracks with MORE toe-in on the Left Rear tire than the Right so the rear of the car helps turn the car LEFT under acceleration.

Wheelbase (Front End): Wheelbase is the distance between the front and rear axles. Running the entire front end assembly in the forward position makes the wheelbase longer and therefore more stable on long/fast tracks with flowing turns. Running the entire front end assembly in the rear position make the wheelbase shorter and therefore more suitable for short-tracks where you are constantly turning.

Wheelbase (Rear End): This adjustment uses the plastic spacers on the kingpin the rear bearing carrier rides on. With the spacers in front of the carrier it will lengthen the wheelbase but will increase steering. If the spacers are behind the carrier it will shorten the wheelbase but increase rear traction. This is completely backwards from how it works for the Front End only because in the rear of the car you have the weight of the motor and the torque it creates. Shortening the wheelbase here makes more of the car hang over the rear tires and promotes more weight transfer.

Final Drive Chart: The chart provided below gives you the final drive of the motor to spin the axle 1 revolution. This chart is NOT just the pinion and spur, but has the transmission ratio included as well.

- To determine the final drive in your car:

- 1) Divide the Spur Gear by the Pinion Gear, which equals a "Ratio".
- 2) Multiply the "Ratio" by the "Transmission Ratio" which will equal your "Final Drive".

Transmission Ratio = 2.4 for this car.

- Gearing choice can vary greatly depending on track size, surface type, amount of traction, you motor and driving style. For starters consult your local hobby dealer or fellow racer at your local track for the ideal gear choice for your application.

64 Pitch Pinion	Spur Gear							
	78	81	85	88	93	96	100	104
16	11.70	12.15	12.75	13.20	13.95	14.40	15.00	15.60
17	11.01	11.44	12.00	12.42	13.13	13.55	14.12	14.68
18	10.40	10.80	11.33	11.73	12.40	12.80	13.33	13.87
19	9.85	10.23	10.74	11.12	11.75	12.13	12.63	13.14
20	9.36	9.72	10.20	10.56	11.16	11.52	12.00	12.48
21	8.91	9.26	9.71	10.05	10.63	10.97	11.43	11.89
22	8.51	8.84	9.27	9.60	10.15	10.47	10.91	11.35
23	8.14	8.45	8.87	9.18	9.70	10.02	10.43	10.85
24	7.80	8.10	8.50	8.80	9.30	9.60	10.00	10.40
25	7.49	7.78	8.16	8.45	8.93	9.22	9.60	9.98
26	7.20	7.48	7.85	8.12	8.58	8.85	9.23	9.60
27	6.93	7.20	7.56	7.82	8.27	8.53	8.89	9.24
28	6.69	6.94	7.29	7.54	7.97	8.23	8.57	8.91
29	6.46	6.70	7.03	7.28	7.70	7.94	8.28	8.61
30	6.24	6.48	6.80	7.04	7.44	7.68	8.00	8.32
31	6.04	6.27	6.58	6.81	7.20	7.43	7.74	8.05
32	5.85	6.08	6.38	6.60	6.98	7.20	7.50	7.80
33	5.67	5.89	6.18	6.40	6.76	6.98	7.27	7.56
34	5.51	5.72	6.00	6.21	6.56	6.78	7.06	7.34
35	5.35	5.55	5.83	6.03	6.38	6.58	6.86	7.13
36	5.20	5.40	5.67	5.87	6.20	6.40	6.67	6.93
37	5.06	5.25	5.51	5.71	6.03	6.23	6.49	6.75
38	4.93	5.12	5.37	5.56	5.87	6.06	6.32	6.57
39	4.80	4.98	5.23	5.42	5.72	5.91	6.15	6.40
40	4.68	4.86	5.10	5.28	5.58	5.76	6.00	6.24
41	4.57	4.74	4.98	5.15	5.44	5.62	5.85	6.09
42	4.46	4.63	4.86	5.03	5.31	5.49	5.71	5.94
43	4.35	4.52	4.74	4.91	5.19	5.36	5.58	5.80
44	4.25	4.42	4.64	4.80	5.07	5.24	5.45	5.67
45	4.16	4.32	4.53	4.69	4.95	5.12	5.33	5.55
46	4.07	4.23	4.43	4.59	4.85	5.01	5.22	5.43
47	3.98	4.14	4.34	4.49	4.75	4.90	5.11	5.31

48 Pitch Pinion	Spur Gear							
	66	68	70	72	75	78	81	84
12	13.20	13.60	14.00	14.40	15.00	15.60	16.20	16.80
13	12.18	12.55	12.92	13.29	13.85	14.40	14.95	15.51
14	11.31	11.66	12.00	12.34	12.86	13.37	13.89	14.40
15	10.56	10.88	11.20	11.52	12.00	12.48	12.96	13.44
16	9.90	10.20	10.50	10.80	11.25	11.70	12.15	12.60
17	9.32	9.60	9.88	10.16	10.69	11.01	11.44	11.86
18	8.80	9.07	9.33	9.60	10.00	10.40	10.80	11.20
19	8.34	8.59	8.84	9.09	9.47	9.85	10.23	10.61
20	7.92	8.16	8.40	8.64	9.00	9.36	9.72	10.08
21	7.54	7.77	8.00	8.23	8.57	8.91	9.26	9.60
22	7.20	7.42	7.64	7.85	8.18	8.51	8.84	9.16
23	6.89	7.10	7.30	7.51	7.83	8.14	8.45	8.77
24	6.60	6.80	7.00	7.20	7.50	7.80	8.10	8.40
25	6.34	6.53	6.72	6.91	7.20	7.49	7.78	8.06
26	6.09	6.28	6.46	6.65	6.92	7.20	7.48	7.75
27	5.87	6.04	6.22	6.40	6.67	6.93	7.20	7.47
28	5.66	5.83	6.00	6.17	6.43	6.69	6.94	7.20
29	5.46	5.63	5.79	5.96	6.21	6.46	6.70	6.95
30	5.28	5.44	5.60	5.76	6.00	6.24	6.48	6.72
31	5.11	5.26	5.42	5.57	5.81	6.04	6.27	6.50
32	4.95	5.10	5.25	5.40	5.63	5.85	6.08	6.30
33	4.80	4.95	5.09	5.24	5.45	5.67	5.89	6.11
34	4.66	4.80	4.94	5.08	5.29	5.51	5.72	5.93
35	4.53	4.66	4.80	4.94	5.14	5.35	5.55	5.75

